

AutoJet® ES250 Electrostatic Chain Oiler System

OWNER'S MANUAL

AutoJet
TECHNOLOGIES



Spraying Systems Co.®
Experts in Spray Technology

ML00ES250F
spray.com

TABLE OF CONTENTS

1. Preface	3
1.1 Important	3
1.2 How To Use This Manual	3
2. Safety	3
2.1 General Safety Information	3
2.2 Unpacking the System	4
3. ES250 Overview	5
3.1 Electrostatics Spraying Overview	5
3.2 System Components and Installation Requirements	5
4. Electrostatic Spray Control Panel	6
4.1 Mounting the Panel and Door Diagram	6
4.2 Connecting the High Voltage Cable	7
4.3 Circuit Board (PCB) and Terminal Block Diagram	8
4.4 Input Details	11
4.5 Output Details	13
4.6 Potentiometers	16
4.7 System Modes	16
4.8 Optional PCB Inputs and Connections	18
4.9 Verifying the Spray Control Panel Set Up	19
5. Fluid Reservoir Assembly	20
5.1 Mounting and Positioning	20
5.2 Fluid Reservoir Connections	21
5.3 Lubricant Pump	22
5.4 Components	23
5.5 Air Pressure Regulator	23
5.6 Particulate Filter	25
5.7 Verifying the Fluid Reservoir Assembly Set Up	25
6. Electrostatic Chain Oiler Spray Nozzle	26
6.1 Nozzle Overview	26
6.2 Nozzle Connections	27
6.3 Nozzle Disassembly Procedure	27
6.4 Nozzle Configuration and Adjustment	28
7. Faults and Troubleshooting	29
7.1 Faults and Fault Codes	29
7.2 Fault LED Status	30
7.3 General System Troubleshooting	32
7.4 Arc Fault Troubleshooting	33
8. Spare and Replacement Parts	34

SECTION 1

PREFACE

1.1 IMPORTANT

The AutoJet[®] ES250 Electrostatic Chain Oiler System and its components are produced, tested, and checked at the factory. The system can be dangerous if used incorrectly. Read this manual carefully and pay special attention to any safety instructions.

Operators must always follow the general safety instructions in the working area and aim to prevent accidents.

The manufacturer reserves the right to make changes in standard construction without prior notification.

Images and diagrams in this manual may not be exact representations of your system configuration.

1.2 HOW TO USE THIS MANUAL

This manual is intended to be a source of information for the operators and technicians who may be installing, interacting with or servicing/maintaining Spraying Systems Co.[®] systems and components.

This manual contains important safety warnings, installation instructions, operating instructions, troubleshooting and maintenance information.

ICONS



WARNING: The user can be seriously injured, damage their health, and/or damage the system.



CAUTION: Product, process, or environment can be damaged or be in danger if the instructions are not followed correctly.



ATTENTION: Supplementary information for the user that draws attention to possible problems.

SECTION 2

SAFETY

2.1 GENERAL SAFETY INFORMATION

READ AND FOLLOW INSTRUCTIONS

All safety-related and operating instructions should be read before the system is operated. Follow all operating instructions.

SERVICING

Do not attempt to service this system unless you have been trained or authorized to conduct repairs. Only authorized and qualified service personnel should attempt to service this system. Service by unauthorized personnel may void any and all warranties.



WARNING: Before performing any maintenance, make sure electrical power is off and any air/liquid pressure is bled from the system.

REPLACEMENT PARTS

This system has been designed with components that work together to provide the best system performance. When replacement parts are required, only Spraying Systems Co.[®] recommended components should be used to maintain proper system operation, electrical and pneumatic safety. The use of any unauthorized replacement parts will void any warranties.

UNINTENDED USE

Use of Spraying Systems Co.[®] equipment in ways other than those described in the documentation supplied with the equipment may result in injury to persons or damage to property. Examples of unintended use of equipment:



- Using incompatible materials or damaged parts
- Making unauthorized modifications or using unapproved auxiliary equipment
- Removing or bypassing safety guards or interlocks
- Operating equipment in excess of maximum ratings

REGULATIONS AND APPROVALS

Make sure all equipment is rated and approved for the environment in which it is used. Any approvals obtained for Spraying Systems Co. equipment will be voided if instructions for installation, operation, and service are not followed. All phases of equipment installation must comply with federal, state, and local codes.

PERSONAL PROTECTIVE EQUIPMENT

Spraying Systems Co.® strongly recommends the use of appropriate safety equipment when working in potentially hazardous environments and chemicals. This safety equipment includes, but is not limited to, the following:

- Protective hat, chemical-resistant safety gloves, and apron
- Safety glasses/face shield, long sleeve shirt and long pants

Users of this product should never place themselves in the path of the spray. Users should consult and follow the recommendations of the Safety Data Sheet (SDS) of any chemical or fluid sprayed using this system.

PRESSURIZED SYSTEMS

It is important to recognize proper safety precautions when using a pressurized spray system. When dealing with pressure applications, the system pressure should never exceed the lowest rated component. Always know your system, all component capabilities, maximum pressures and flow rates.



WARNING: Fluids under pressure can penetrate skin and cause severe injury.



ATTENTION: Always remember to carefully read the chemical manufacturer's labels, follow SDS and all directions.

WARNING OF SHOCK HAZARD

To reduce the risk of electric shock, do not open the cover on electrical control panel. For service contact Spraying Systems Co.® at 1-866-321-2250.



WARNING: Plug panels into A GFCI outlet.



WARNING: To prevent injury, avoid contact with potentially hot parts. Components can cause severe burns. Do not aim the spray at any person or part of the body. Do not place any part of your body into the spray pattern.

USE OF CHEMICAL COMPONENTS

Spraying Systems Co. does not manufacture or supply any of the chemical components used in this equipment and is not responsible for their effects. Because of the large number of chemicals that could be used and their different chemical reactions, the buyer and user of this equipment should determine compatibility of the materials used and any of the potential hazards involved.

2.2 UNPACKING THE SYSTEM

The system components come carefully packaged to protect them from damage. Use caution when opening the crate. The crate will contain all parts needed to install the unit. Parts of the unit may be wrapped in bubble wrap. Remove all of the packaging material wrapping the system. Once unpacked and removed from the crate, the system is ready for installation and connection.



CAUTION: The packaging may contain exposed cables, hoses, and other components. Always exercise caution when opening boxes to avoid accidental damage or slicing of various components.



ES250 OVERVIEW

3.1 ELECTROSTATICS SPRAYING OVERVIEW

In electrostatic spraying, a negative charge is introduced into a fluid in the nozzle body through a central charging electrode, which causes the fluid to acquire a negative charge. When this negative charge is applied to the fluid, this causes the fluid molecules to repel each other, following the principle that molecules with opposite charges will attract and molecules with like charges will repel. Electrostatic spraying relies on the repulsion of these like-charged small fluid droplets.

After leaving the nozzle orifice, the fluid molecules continue to repel each other as they travel, causing the already small droplets to break up into even smaller droplets. This process will continue until the repulsive force between the molecules is no longer strong enough to break the surface tension and split the droplet again.

These tiny and uniformly sized droplets retain their negative charges and will be attracted to any neutral, grounded target nearby with an attractive force stronger than gravity. Electrostatic forces pull the liquid molecules towards this target, thinly and evenly coating the target surface and providing a very high fluid transfer efficiency

Some benefits of electrostatic spraying include:

- Low flow rates that allow for less fluid usage
- Reduced product and workspace contamination due to overspray
- Shorter workspace cleanup times
- Longer intervals between system maintenance
- More uniform target coatings, typically achieving over 90% transfer efficiency

3.2 SYSTEM COMPONENTS AND INSTALLATION REQUIREMENTS

This electrostatic system includes the following main components:

- AutoJet[®] ES250 Electrostatic Spray Control Panel
- Fluid Reservoir Assembly
- Electrostatic Chain Oiler Spray Nozzle

CUSTOMER REQUIREMENTS FOR INSTALLATION

- Mounting locations for all components that meet any and all national or local safety standards
- 40 psi (minimum) shop air connection
- 24 VDC power supply to provide power to the control panel's circuit board, the solenoid valve connection, and the high voltage power supply (HVPS) —2.5 amp minimum

REQUIRED TOOLS FOR INSTALLATION

- 15 mm open ended wrench and 27 mm open ended wrench.
- Slotted screwdriver 3/8" (9.5 mm) or larger for accessing the panel)
- #2 Phillips head screwdriver (for removing the high voltage terminal block enclosure cover)
- #2 Square bit screwdriver or 3/8" (9.5 mm) slotted screwdriver (for tightening high voltage terminals)
- 1/8" (0.125 mm) slotted screwdriver (for terminals)
- Wire strippers



ELECTROSTATIC SPRAY CONTROL PANEL

SPRAY CONTROL PANEL

The AutoJet® ES250 Electrostatic Spray Control Panel supplies the required voltage to the electrostatic nozzles via a 30,000 VDC (30 kVDC) negative polarity HVPS. At the control panel, the operator can adjust the applied voltage, pump frequency and start or stop the system modes.

GASKET

The control panel has a gasket installed which creates a seal between the door and the body of the unit. Exercise caution when opening the unit door as to not damage the gasket. Debris inside the control panel may cause damage to the system.

4.1 MOUNTING THE PANEL AND DOOR DIAGRAM

MOUNTING

When selecting a control panel mounting location, consider the high voltage cable routing required and your purchased cable length in relation to the nozzle mounting location. Make sure the control panel is mounted within an acceptable distance to the nozzle, it is easily accessible to system operators, and the grounding lug is connected to a grounded GFCI outlet (Figure 4.1).

If mounting the panel to the wall, in a location that is close to your nozzles install wall anchors that are designed to support at least 25 lbs. (11.34 kg) according to the anchor manufacturer’s specifications. The mounting holes are on 6” (152 mm) centers and are made for 1/4” (6 mm) screws with 3/8” (10 mm) diameter screw heads (Figure 4.1-1).



Figure 4.1: Grounding lug

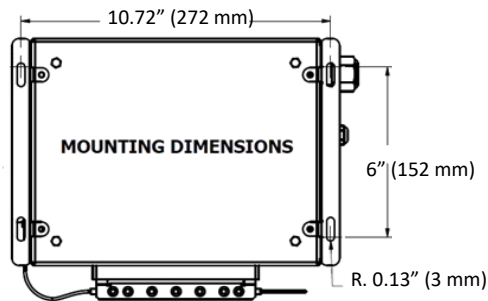

Figure 4.1-1: Dimensions and mounting hole pattern

SPRAY CONTROL PANEL DOOR LABELED DIAGRAM

The control panel door uses illuminating pushbuttons to relay system information. The POWER switch will illuminate when system power is on. The RESET and STOP pushbuttons will illuminate related to system operation and fault status (Figure 4.1-2).

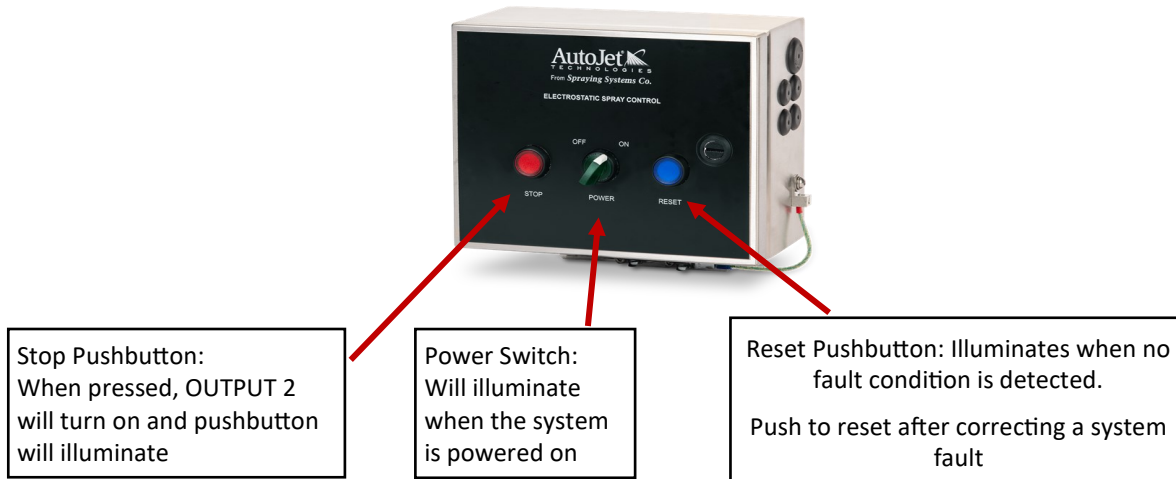

Figure 4.1-2: Labeled control panel door diagram

The reset pushbutton strobes and follows the run sequence. This means that while the system is lubricating, the pushbutton will strobe in sync with the stroke of the piston pump. When the system stops lubricating but the power remains on, the pushbutton returns to a constant illumination.

If a fault is detected, the reset pushbutton will cease illumination and the stop pushbutton will begin to illuminate. The stop pushbutton will pulse in accordance with the number of pulses that have been set for the detected system fault.

See Section 7.1 Faults and Fault Codes for more information.

4.2 CONNECTING THE HIGH VOLTAGE CABLE



WARNING: Before installation, ensure that the spray control panel is turned off and power is disconnected.



CAUTION: Make sure high voltage cables are properly grounded. Failure to ground may cause a power surge on the system and damage the control board.

SUGGESTED TOOLS

- A properly sized adjustable wrench (for cord grips)
- Slotted screwdriver (3/8" or larger for accessing the panel)
- #2 Phillips head screwdriver (for removing the high voltage terminal block enclosure cover)
- 1/8" Slotted screwdriver (for terminals)
- Wire strippers

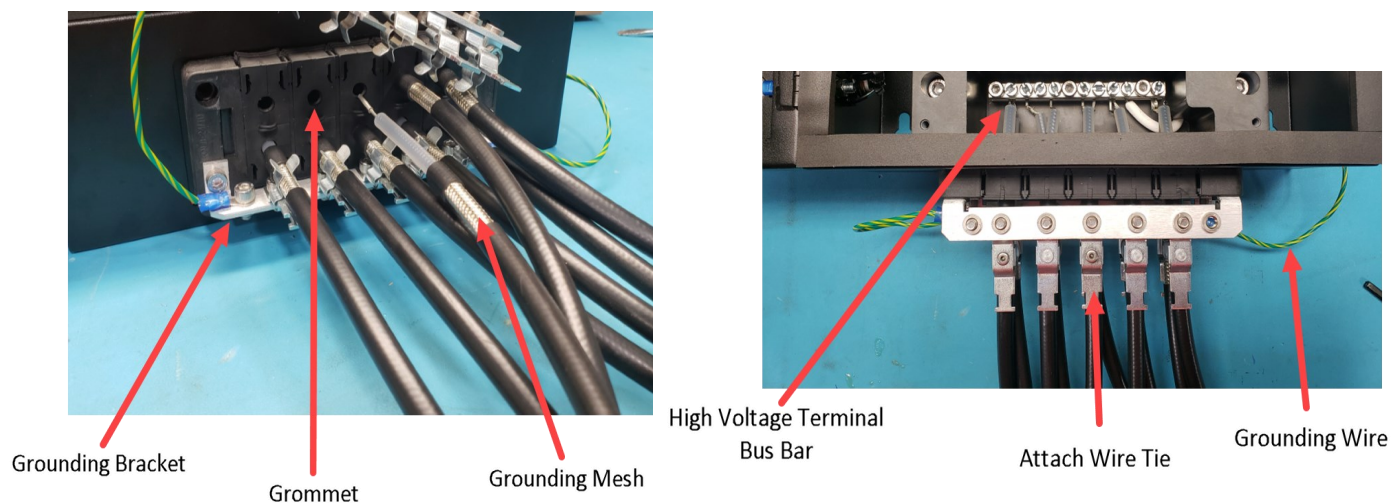

Figure 4.2: Connecting the high voltage cables to the spray control panel.

CABLE CONNECTION PROCESS

- Remove high voltage block cover and silicone gasket
- Slide cables through the grommets in the bottom of the control box
- Connect cables to the high voltage terminal block bus bar
- Push cables into clamps on the grounding bracket, confirm grounding mesh is in clip
- Attach wire tie around cable and clip
- Make sure grounding wire is connected from grounding bracket to grounding lug and reinstall cover and silicone gasket



4.3 CIRCUIT BOARD (PCB) AND TERMINAL BLOCK DIAGRAMS

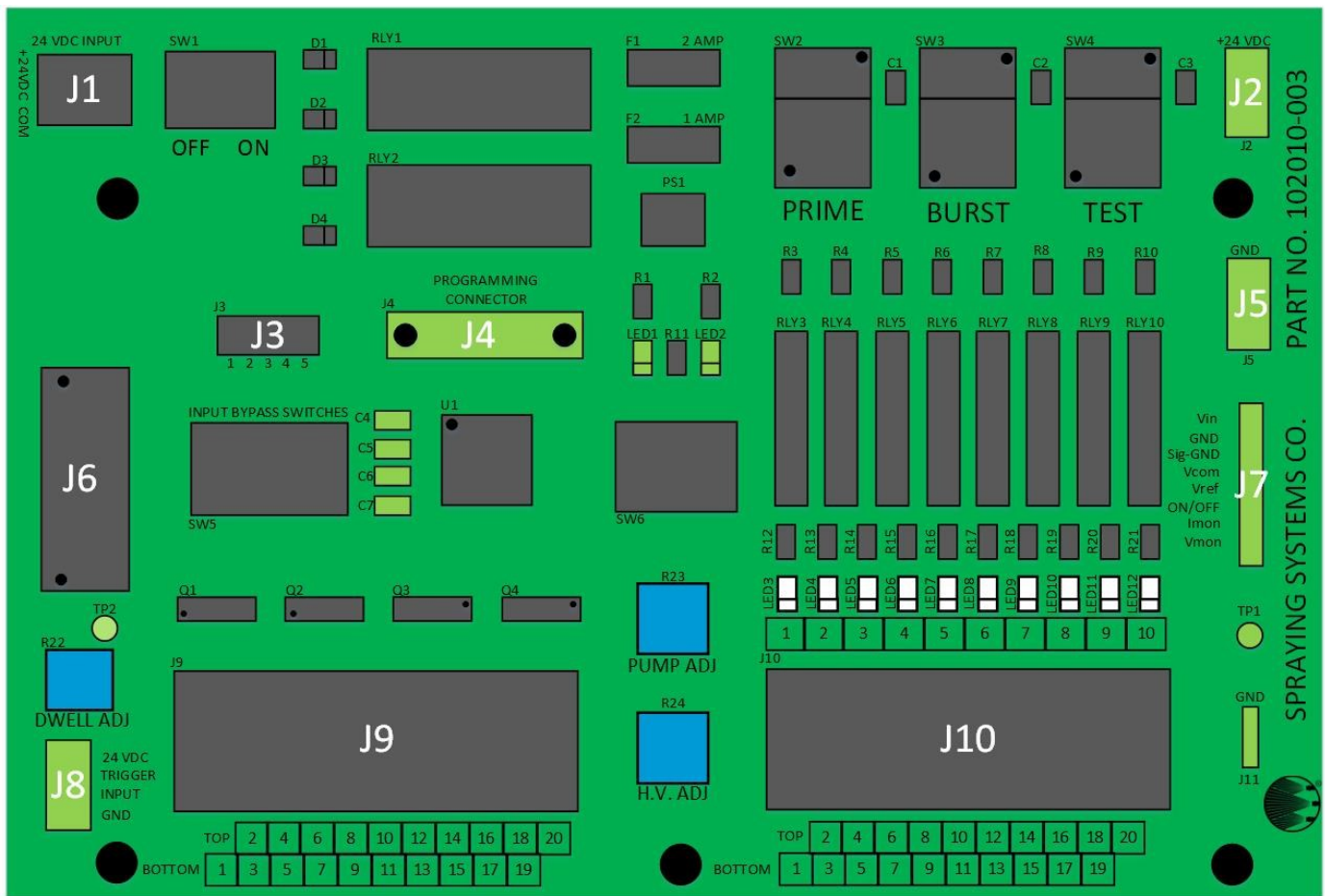

Figure 4.3-1: PCB diagram

PCB TERMINAL BLOCK INFORMATION

The following table contains PCB terminal block descriptions.

J1	Input power connection 24 VDC, 2.5 amp. (Customer supplied)
J2	24 VDC Source
J3	Factory Use Only Jumpers must be installed in slots 4 and 5
J4	Factory Use Only
J5	Ground Connection Provides a ground for components powered by block J2
J6	Panel Pushbuttons & Indicators See Page 10 for diagram
J7	High Voltage Power Supply See Page 10 for diagram
J8	Factory Use Only Trigger Input
J9	Input Connections See Page 11 for diagram
J10	Output Connections See Page 13 for diagram

TERMINAL BLOCK J1

Terminal Block J1 is used to provide power to the spray control panel via the connector.

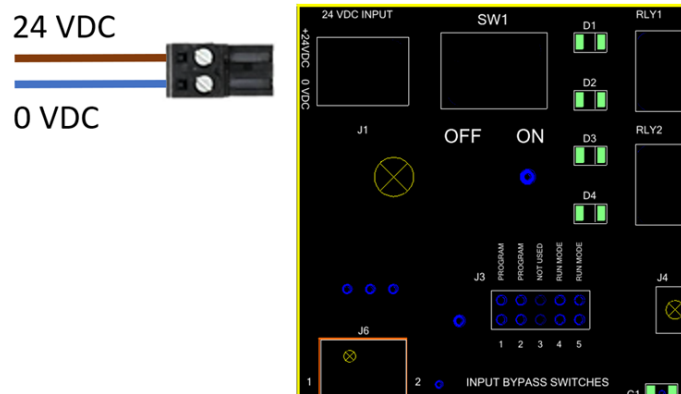

Figure 4.3-2: Location and connector for Terminal Block J1.

TERMINAL BLOCK J2 AND J5 EXAMPLE DIAGRAM

Block J2 provides 24 VDC only and Block J5 is ground only.

This provides the option to power components such as proximity sensors or pressure switches. If your system configuration does not require or necessitate the use of external components, Blocks J2 and J5 will likely go unused.

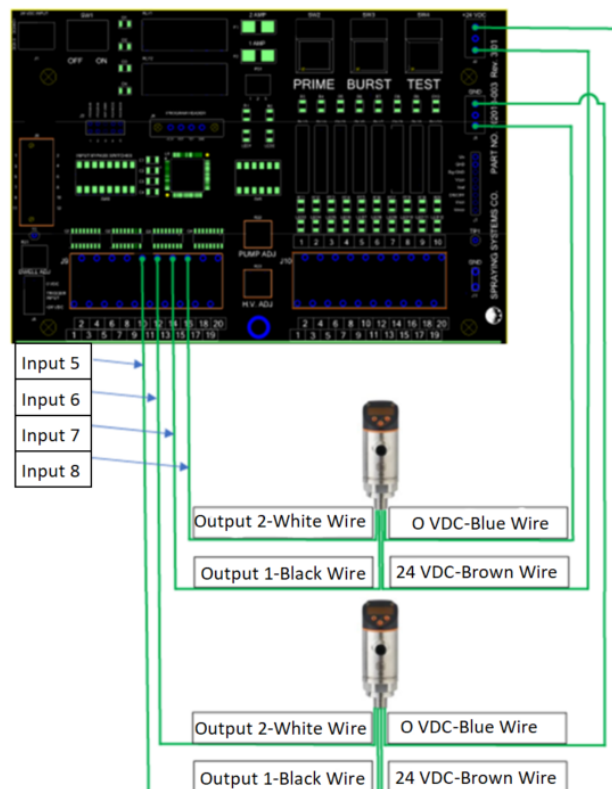
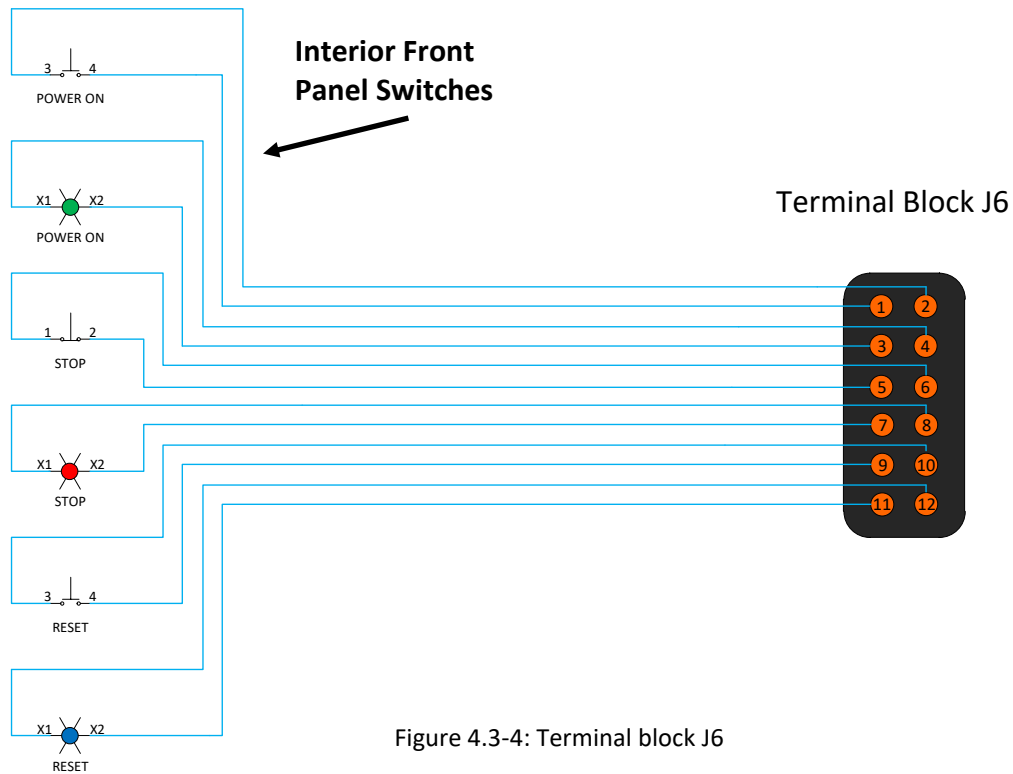
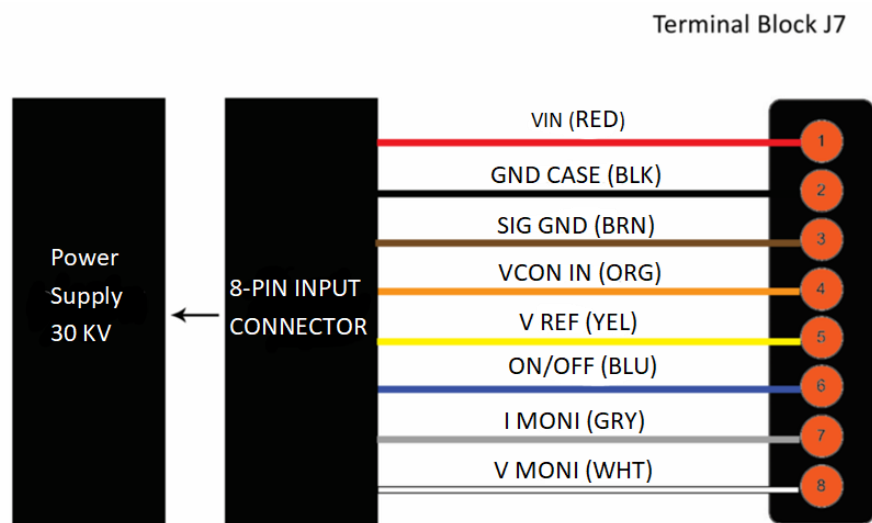

Figure 4.3-3: Example diagram for connecting external pressure transducers (or any other components) to the system

SPRAY CONTROL PANEL DOOR SWITCH AND INDICATOR DIAGRAM—BLOCK J6



HIGH VOLTAGE CONNECTION DIAGRAM—BLOCK J7 CONNECTION REFERENCE*



*Connections come landed from factory.

4.4 INPUT DETAILS



WARNING: Maximum temperature rating 120°F (49°C)



ATTENTION: The Electrostatic Spray Control Panel requires a customer supplied 24 VDC, 2.5 A.

Inputs 1 thru 10 require 24 VDC and 1.25 mA to energize.

INPUT CONNECTIONS: J9 TERMINAL BLOCK

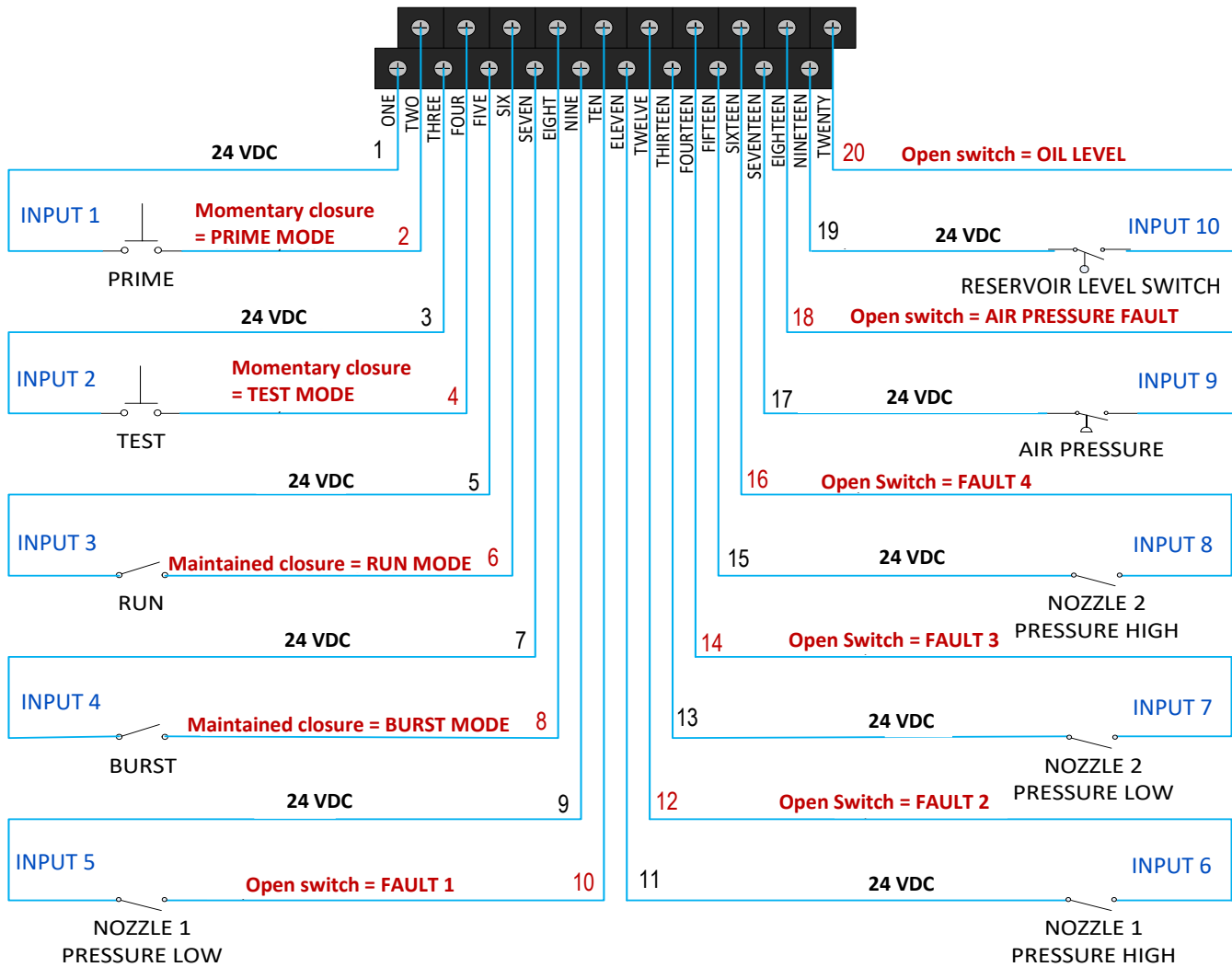

Figure 4.4-1: Input connections



INPUT DESCRIPTIONS: J9 TERMINAL BLOCK

Not all inputs need to be used. The user should determine which inputs are most important for the application.

Odd numbered connections are for +24 VDC power source; even numbered connections are for connection to positive side of the load.

INPUT	TERMINAL CONNECTION	DESCRIPTION
1	1 & 2	Momentary Closure = PRIME MODE A momentary closure in this circuit activates PRIME MODE. (ref. prime mode description in System Modes section)
2	3 & 4	Momentary Closure = TEST MODE A momentary closure in this circuit activates TEST MODE. (ref. test mode description in System Modes section)
3	5 & 6	Maintained Closure = RUN MODE A momentary closure in this circuit activates RUN MODE. (ref. run mode description System Modes section)
4	7 & 8	Maintained Closure = BURST MODE A momentary closure in this circuit activates BURST MODE. (ref. burst mode description System Modes section)
5	9 & 10	Open Switch = FAULT 1 For use with pressure sensors. System will fault when pressure is below range.
6	11 & 12	Open Switch = FAULT 2 For use with pressure sensors. System will fault when pressure is above range.
7	13 & 14	Open Switch = FAULT 3 For use with pressure sensors. System will fault when pressure is below range.
8	15 & 16	Open Switch = FAULT 4 For use with pressure sensors. System will fault when pressure is above range.
9	17 & 18	Open Switch = AIR PRESSURE FAULT Air pressure guage/sensor to be wired here. System faults if air pressure falls below set limit on the guage/sensor.
10	19 & 20	Open Switch = OIL LEVEL Level switch wired here. System will fault when level switch is active. Note: Wire colors and terminals.

4.5 OUTPUT DETAILS

OUTPUT CONNECTIONS: TERMINAL J10

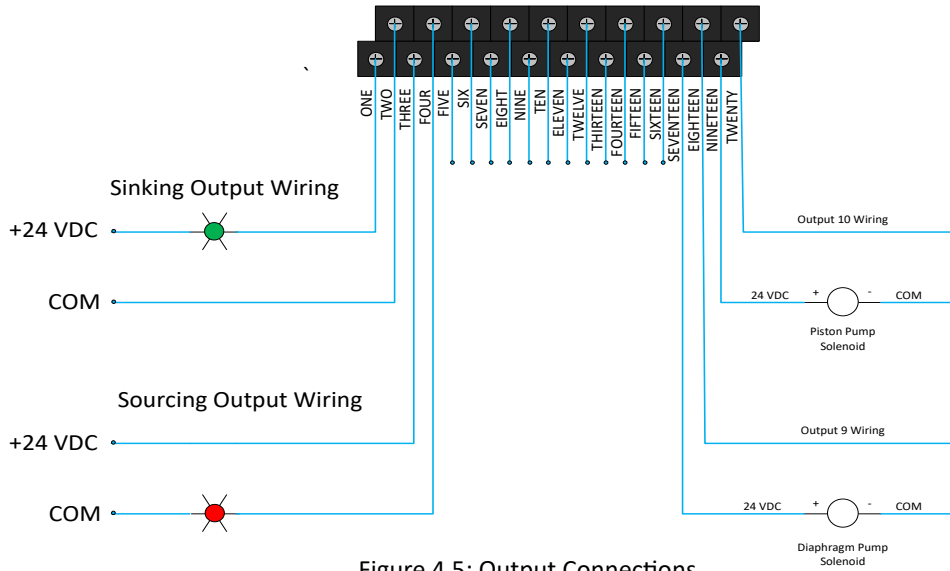

Figure 4.5: Output Connections

These outputs contain PTC Thermistors with a trip rating of 750 mA at 20 °C (68 °F). The PTC Thermistor current passing capacity must be de-rated 10 percent for each 10 °C increase in ambient temperature.

Example:

The ambient temperature where the control panel is used is 30 °C (86 °F).

The outputs will be de-rated by 10 percent for the 10 °C increase.

$$(750 \text{ mA}) (.90) = 675 \text{ mA}$$

Outputs 9 and 10:

24 VDC designated outputs, these outputs are powered directly through the circuit board.

These outputs contain PTC Thermistors with a trip rating of 200 mA at 20° C (68° F). The PTC Thermistor current passing capacity must be de-rated 10 percent for each 10° C increase in ambient temperature.

Example:

The ambient temperature where the control panel is used is 30° C (86° F).

The outputs will be de-rated by 10 percent for the 10°C increase.

$$(200 \text{ mA}) (.90) = 180 \text{ mA}$$

OUTPUT DESCRIPTIONS: TERMINAL J10

Not all outputs need to be used. The user should determine which outputs are most important for the application.

Odd numbered connections are for +24 VDC power source; even numbered connections are for connection to positive side of the load.

OUTPUT	TERMINAL CONNECTION	DESCRIPTION
1	1 & 2	SYSTEM HEALTHY Energized when the spray control panel is powered on and there are no fault conditions present. Any fault condition will de-energize Output 1. The System Healthy output is the best way to monitor system status as any alarm and/or power loss will de-energize this output.
2	3 & 4	GENERAL FAULT Energized when there is a system fault condition present. Output 2 can be used as an indicator that a fault has occurred and is the opposite of Output 1.
3	5 & 6	FAULT CODE Sends a series of pulses to indicate a precise fault that occurs. Output 3 can be connected to a PLC input and used to determine the precise fault that has occurred by interpreting the Output 3 pulse code.
4	7 & 8	ARC FAULT Energizes if the spray control panel detects a brief current surge through the HVPS.
5	9 & 10	NOZZLE PRESSURE FAULT Energized any time one of the nozzle pressure inputs (5, 6, 7, 8) indicates unsatisfactory nozzle pressure.
6	11 & 12	AIR PRESSURE FAULT Energized if the air pressure drops below the setting of the air pressure switch.
7	13 & 14	LOW RESERVOIR FAULT Energized when the reservoir fluid level drops below the reservoir level switch.
8	15 & 16	FACTORY USE ONLY
9	17 & 18	LUBE CYCLE ON Energized when the system is in Lubrication, Prime, or Test Mode. The output can be used to energize the solenoid valve to a diaphragm pump or a stack light indicating the system status.
10	19 & 20	PISTON PUMP Provides a low frequency pulse to the piston pump solenoid. The pulse will be output anytime the spray control panel is in Lubrication, Prime, or Test mode. The frequency of the output is controlled by the Pump Adjust Potentiometer on the PCB.

INPUT BYPASS SWITCHES (DIP SWITCH)

Input Bypass Switches allow system operators to toggle Inputs 3-10 on or off. The table below offers a short description of each switch, and lists the factory recommended switch setting if appropriate.

Dip Switch Name	Switch Position
Switch 1 – Input 3 bypass	On: Constant Lubrication Mode Off: If providing external Lubrication mode input (Recommended)
Switch 2 – Input 4 bypass	On: Constant Burst Mode Off: If providing external Burst Mode input (Recommended)
Switch 3 – Input 5 bypass	On: If not using Nozzle 1 Low Pressure Alarm Off: If Nozzle 1 Low Pressure Alarm is in use
Switch 4 – Input 6 bypass	On: If not using Nozzle 1 High Pressure Alarm Off: If Nozzle 1 High Pressure alarm is in use
Switch 5 – Input 7 bypass	On: If not using Nozzle 2 low pressure alarm Off: If Nozzle 2 low pressure alarm is in use
Switch 6 – Input 8 bypass	On: If not using Nozzle 2 high pressure alarm Off: If Nozzle 2 high pressure alarm is in use
Switch 7 – Input 9 bypass	On: If not using Air Pressure Switch Off: If Air Pressure Switch is in use (Recommended)
Switch 8 – Input 10 bypass	On: If not using Reservoir Level Switch Off: If Reservoir Level Switch is in use (Recommended)

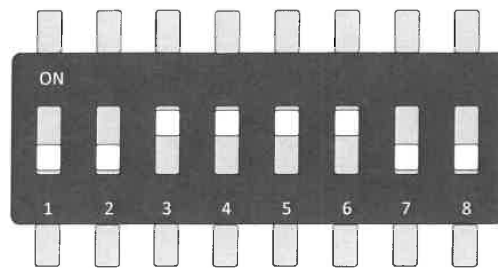

Figure 4.4-2: Input bypass switches in their factory-recommended positions

4.6 POTENTIOMETERS

PUMP Adjustment (PUMP ADJ) – Output 10

The PUMP ADJ potentiometer is used to increase or decrease the frequency of Output 10 which affects the pump frequency. The pump frequency is adjustable from 20 – 80 cycles per minute.

Rotating the potentiometer dial **clockwise** will increase the output frequency.

Rotating the potentiometer dial **counterclockwise** will decrease the output frequency.

HIGH Voltage Adjustment (H.V. ADJ)

The H.V. ADJ potentiometer is used to increase or decrease the output of the High Voltage Power Supply. The High Voltage Power Supply is adjustable from 0 – 30,000 VDC.

Rotating the potentiometer dial **clockwise** will increase the high voltage output.

Rotating the potentiometer dial **counterclockwise** will decrease the high voltage output.

Measuring Exact Output Voltage

The High Voltage Power Supply output can be determined by measuring the DC Voltage across TP1 (Test Point 1) and Ground. The DC Voltage will be a reference between 0 and 5.0 VDC. To determine the actual High Voltage Output multiply the Voltage across TP1 and Ground times 6 kV/volt.

Example:

Voltage across TP1 is measured as 2.2 VDC

$(2.2 \text{ volts}) (6 \text{ kV/volt}) = 13.2 \text{ kV}$

$= 13,200 \text{ VDC}$

DWELL Adjustment (DWELL ADJ)

Factory use only, corresponds with Output 8.



Figure 4.6: PUMP & High Voltage ADJ Potentiometers

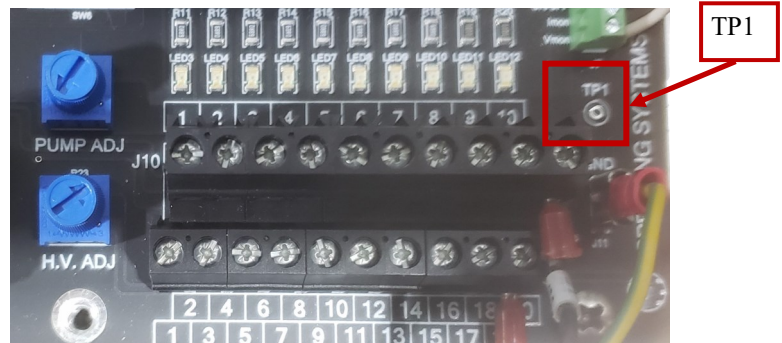

4.7 SYSTEM MODES

PRIME MODE

Terminal Block J9 - INPUT 1 - Connection 1 & 2 and/or PCB Mounted Pushbutton

Prime mode - will cycle the pump outputs for a period of 60 minutes and should be used during system installation or the fluid lines to the nozzles need to be filled prior to spraying. The pump cycle during Prime mode is 120 CPM.

Note: It may require several Prime mode cycles before fluid reaches the nozzle opening, depending on selected fluid line length, flow rate, and fluid viscosity.

Terminal block J9 -Input 1 is intended for a *customer-installed* normally-open momentary pushbutton (Optional). Input 1 will only be active if the system is in Standby Mode. This means that the system cannot be in Lubrication Mode, Burst Mode, Test Mode, or any fault condition.

—The PCB mounted PRIME pushbutton will be fully functional whether or not Block J9, Input 1 is connected.



Figure 4.7-1: PCB PRIME button

If the system is in Prime mode, the following will occur:

- Output 9 will be energized (lubrication on)
- Output 10 will output a 120 cycle per minute pulse train to rapidly cycle the piston pumps
- The Blue LED indicator on the control panel door will strobe in sync with Output 10
- The Red LED indicator on the PRIME pushbutton located on the PCB will be illuminated, indicating that the system is in Prime mode
- HVPS will be disabled
- Nozzle 1 & 2 Pressure Low and Pressure High inputs will be disabled

To exit Prime mode, one of the following must occur:

- The system is put into Lubrication Mode (Input 3 is energized). This automatically terminates Prime mode
- Press the Reset button on the control panel door
- Press the Prime pushbutton located on the printed circuit board
- Momentarily energize Input 1 (Customer Prime mode input)
- The Prime mode cycle timer expires (60 minutes)
- A fault condition (Low air pressure or Low reservoir level)

TEST MODE

Terminal Block J9 - INPUT 2 - Connection 3 & 4 and/or PCB Mounted Pushbutton

Test mode will be active for 15 minutes and should be used to check the system operation anytime when the system is in Standby Mode. This means that the system *cannot* be in Lubrication mode, Burst mode, Prime mode, or under any fault condition.

Block J9, Input 2 is intended for a *customer-installed* normally-open momentary pushbutton (Optional). The PCB mounted button will be fully functional whether or not the input is connected.

If the system is in Test mode, the following will occur:

- Output 9 will be energized (lubrication on)
- Output 10 will output a low frequency pulse train (adjustable by the PUMP ADJ potentiometer) to cycle the piston pumps
- The Blue LED indicator on the control panel door will strobe in sync with Output 10
- The Red LED indicator on the TEST pushbutton located on the PCB will be illuminated indicating that the system is in Test mode
- HVPS will be enabled

To exit Test mode, one of the following must occur:

- The system is put into Lubrication mode (Input 3 energized). This automatically terminates Test mode
- Press the Reset button on the control panel door
- Press the TEST pushbutton located on the printed circuit board
- Momentarily energize Input 2 (Customer Test mode input)
- Test mode 15 minute cycle timer expires
- A fault condition



Figure 4.7-2
PCB TEST

LUBRICATION MODE

Terminal Block J9 - INPUT 3 - Connection 5 & 6

Input 3 is the customer lubrication input. The input can be from a normally-open switch, normally-open relay contacts, or from a PLC output. When the contacts are closed (24VDC is supplied to the input), the system will be in Lubrication mode. When the contacts are open, the system will be in Standby mode.

Lubrication mode will override both *Test* and *Prime* modes. If the Test mode cycle is not complete, and the lubrication input is energized, the system will terminate Test mode and the system will enter Lubrication mode. The system will **not** return to Test mode after the Lubrication mode is terminated.

If the system is in Lubrication mode, the following will occur:

- Output 9 will be energized (lubrication on)
- Output 10 will output a low frequency pulse train (adjustable by the PUMP ADJ potentiometer) to cycle the piston pumps
- The Blue LED indicator on the control panel door will strobe in sync with Output 10
- HVPS will be enabled

To exit Lubrication Mode:

- **Standby mode:** Input 3 must be de-energized and SW5 – Dip Switch 1 is an OFF position
- **Fault mode:** Any system fault occurs
- **System power:** OFF



ATTENTION: Burst will only be active while the system is in Lubrication mode (Input 3 energized).

BURST MODE

Terminal Block J9 - INPUT 4 - Connection 7 & 8 or PCB Mounted Pushbutton

When the BURST pushbutton and Input 4 are activated the system goes into burst mode.

Burst Mode Input - is used to increase the lubrication volume to 1.25x the current pump frequency setpoint for 24 hours (unless placed into a different mode). This allows for a 24-hour period of increased lubrication, when desired, without the need to change the PMP ADJ potentiometer setting. Maximum burst mode frequency is 100 CPM.

When using the PCB Burst mode pushbutton, the red LED indicator will illuminate.

To exit Burst mode, one of the following must occur:

- The Reset button on the control panel door is pressed
- The BURST button on the PCB is pressed
- The 24 hour mode timer expires (PCB Pushbutton)

4.8 OPTIONAL PCB INPUTS AND CONNECTIONS

Terminal Block J8

For factory use only.

Nozzle 1 & 2 Pressure Low & High

Terminal Block J9 - INPUTS 5 through 8 - Connection 9 through 16

Inputs 5 through 8 will activate when the nozzle pressure is inadequate. The system must be in Lubrication mode for 10 seconds before the inputs are enabled. It is intended to be used as nozzle pressure/flow input and allows the pressures to stabilize before allowing a fault condition to occur.



Figure 4.7-3: PCB BURST pushbutton

When a Pressure Fault is detected, the following will occur:

- Output 1 (system healthy) will de-energize
- Output 2 (general fault) will energize indicating a General Alarm
- Output 5 (nozzle pressure fault) will energize
- Outputs 8-10 will de-energize (factory use, lubrication cycle, piston pump)
- The red stop LED will strobe 2 times followed by a pause and repeat
- HVPS will be disabled

To clear the fault, the condition must be corrected and the Reset button must be pressed.

AIR PRESSURE REGULATOR

Terminal Block J9 - INPUT 9 - Connection 17 & 18

Input 9 is used to monitor if the system has adequate air pressure to properly cycle the pumps.

If the air pressure regulator opens (low system air pressure), the system will go into a Low Air Pressure Fault. The following will occur:

- Output 1 (system healthy) will de-energize
- Output 2 (general fault) will energize indicating a General Alarm
- Output 3 (fault code) will strobe 10 times followed by a pause
- Output 6 will energize indicating a “Low Air Pressure Fault”
- Outputs 8-10 (factory use, lubrication cycle, piston pump) will de-energize
- The red stop LED will strobe 10 times followed by a pause
- HVPS will be disabled

To clear the fault, the low air pressure condition must be corrected (provide adequate air pressure) and the “Reset” button pressed.

RESERVOIR LEVEL SWITCH

Terminal Block J9 - INPUT 10 - Connection 19 & 20

When the reservoir level switch opens (low reservoir level), the system will go into a Low Oil Level Fault. The following will occur:

- Output 1 (system healthy) will de-energize
- Output 2 (general fault) will energize indicating a General Alarm
- Output 3 (fault code) will strobe 12 times followed by a pause
- Output 7 will energize indicating a “Low Reservoir Level Fault”
- Outputs 8-10 (factory use, lubrication cycle, piston pump) will de-energize
- The red stop LED will strobe 12 times followed by a pause
- HVPS will be disabled

To clear the fault, the Low Reservoir Fault must be corrected and the “Reset ” button pressed.

4.9 VERIFYING THE SPRAY CONTROL PANEL SET UP

Verify that the following connections have been completed:

- 24 VDC has been connected to Terminal J1, and PCB power switch is in the OFF position
- Both the Spray Control Panel and the target are connected to an “earth” ground or GFCI outlet.



FLUID RESERVOIR ASSEMBLY

5.1 MOUNTING AND POSITIONING

FLUID RESERVOIR ASSEMBLY

The fluid reservoir assembly includes pumps, an air pressure regulator with a built in particle filter, and the fluid reservoir tank.

The piston pump powers lubricant delivery from the reservoir to the nozzle. The pressure regulator with built in particle filter provides clean, controlled air pressure to the pump for its operation. The fluid reservoir tank provides a sealed container for the fluid being sprayed. The reservoir tank allows for the direct mounting of the air pressure regulator and pump. The reservoir tank also incorporates a fluid level sensor that can stop system operation via a system fault when fluid levels drop below a safe operating setpoint.

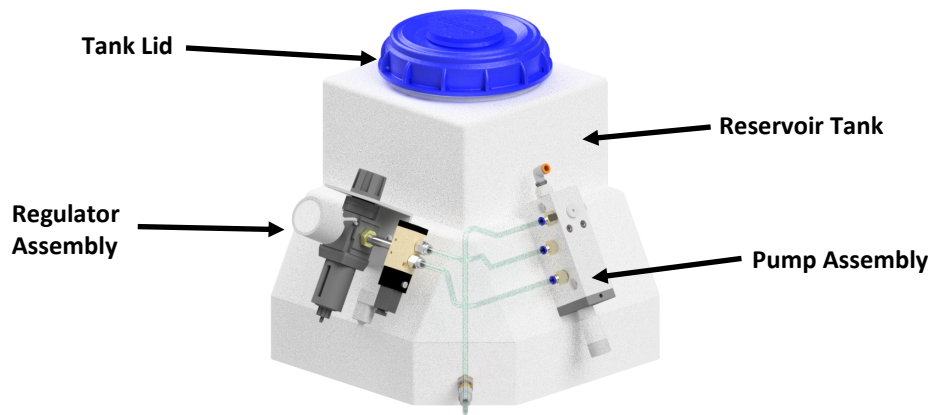

Figure 5.1: Fluid reservoir assembly

With the fluid reservoir system configuration, the components are mounted directly on the reservoir itself. Your system will ship from the factory with the components already installed on the fluid reservoir.

Each electrostatic nozzle is powered by a dedicated pump. You will be able to mount up to four (4) pumps to power up to four (4) nozzles directly to the fluid reservoir tank. If your system configuration includes more than four pumps and nozzles, a Pump Expansion Kit is available that accommodates an additional four pumps.

- The customer will be responsible for supplying and connecting all liquid and air tubing for the system.
- Position the fluid reservoir assembly below the level that the nozzles will be mounted at.
- **The fluid reservoir tank must be positioned within 35 ft of the nozzle mounting location.**
- If your configuration does not include the fluid reservoir tank, the air pressure switch and piston pumps are to be mounted in a clean, non-hazardous area below the nozzle mounting level.



WARNING: Make sure all power is disconnected before making any connections to or from the spray control panel.



ATTENTION: Please follow any local, state, or national regulations for clearance requirements and electrical codes.

5.2 FLUID RESERVOIR CONNECTIONS

FLUID LINES

The fluid line originates from the fluid reservoir and connects to the pump. The line then runs out to the electrostatic nozzle through 1/4 in. OD push-to-connect fittings.

AIR LINES

The air input connects to the air pressure regulator using 1/4 in. NPT. The regulator connects to the pump through 1/4 in. OD push-to-connect (Tube) fittings.

Pump Connections Side View

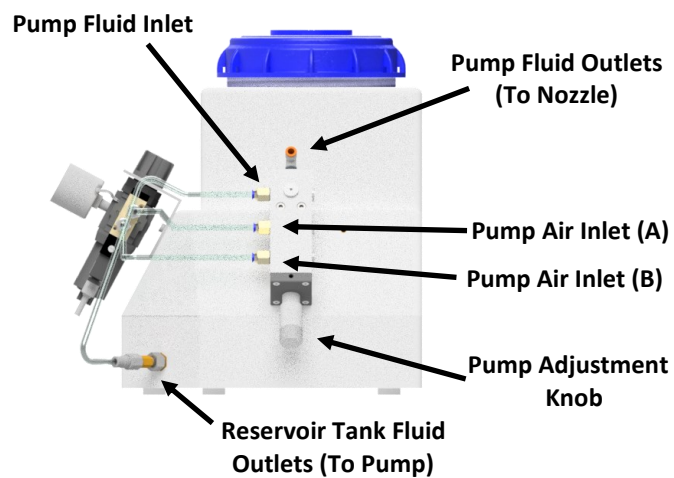

Figure 5.2-1: Pump connection diagram

Air Connections Side View

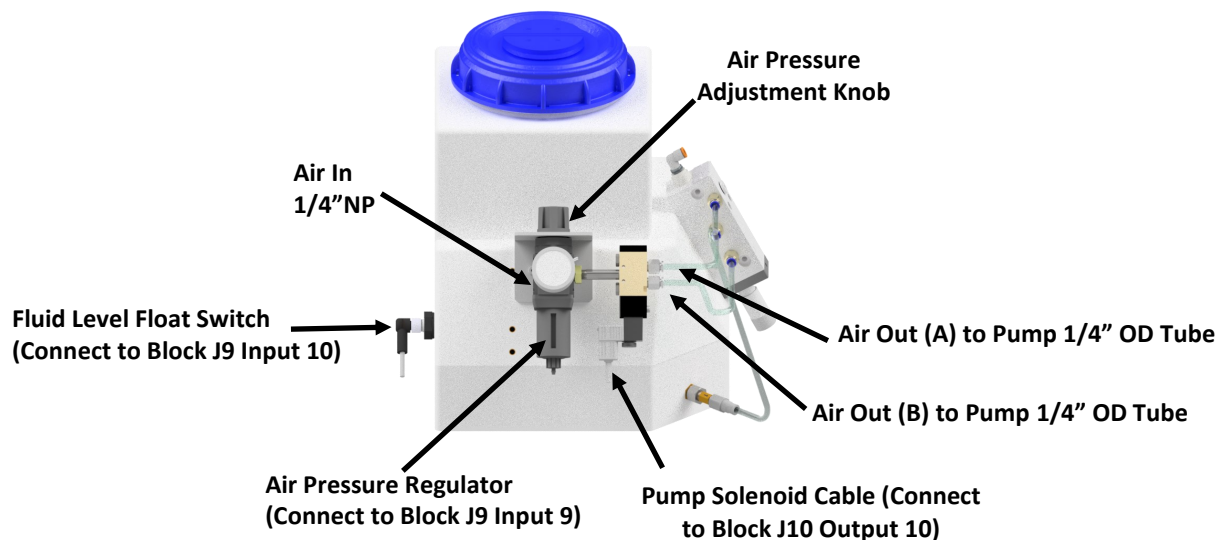

Figure 5.2-2: Air connections diagram

5.3 LUBRICANT PUMP

System fluid delivery is powered by a small piston pump. This type of pump is commonly used in applications when low flow rates are desired for chain lubrication. The system includes an air pressure regulator assembly to power the pump.

PUMP SPECIFICATIONS

The electrostatic nozzles are powered by a piston pump that features two air inlets, one fluid inlet, and one fluid outlet. Pump inlets and the outlet use 1/4 in. OD push-to-connect fittings.

- Pump air pressure limits are between 14.5 - 87 psi.
- Maximum temperature rating is 180°F.
- Pumps feature Viton seals for compatibility with a wide variety of fluids.



Figure 5.3-1: Standard

ADJUSTING THE PUMP

Use the adjustment stem on the bottom of the pump in conjunction with the pump cycle frequency (from the Spray Control Panel) to control the flow rate. The adjustment stem will:

- Extend out from the bottom of the pump, rotating counter-clockwise until the marker shows 20 at its maximum (do not unscrew further, it may damage the pump).
- Tighten clockwise until it cannot be tightened anymore at its lower limit (shortest stroke length)

Note: Pump frequency may depend on the viscosity of lubricant used. Higher viscosity lubricants may require lower pump frequencies.

The Piston Pump Duty Cycle (ON Pulse) is .1s. This rapidly discharges the oil from the pump cylinder and maximizes the suction stroke of the pump, allowing more time for oil to fill the pump cylinder. The duty cycle time is important to consider when connecting solenoids to the piston pump. Incorrect connections can lead to pump failure or stroke disruption.

Standard Pump

- Minimum output, per cycle, per pump: 0.0018 in³ / 0.03 cc / 0.001 oz.
- Maximum output, per cycle, per pump: 0.0366 in³ / 0.6 cc / 0.02 oz.
- When increasing or decreasing the stroke length with the adjustments stem, each mark is a change of 0.0285cc.
- Max flow rate: 48 cc/min

Note: Each pump supplies at least two(2) nozzles, so the flow rates should be cut in half.

5.4 COMPONENTS

FLUID RESERVOIR COMPONENTS

The air pressure switch, solenoid cable, and fluid level float switch are all wired back to the Electrostatic Spray Control Panel.

- The air pressure regulator (Figure 5.4-1) connects Block J9 and Input 9 connecting the black and white wires to terminals 17 and 18 respectively.
- The solenoid cable (Figure 5.4-2) connects Block J10 and Output 10. Black wire is labeled 1 and 2, the 1 wire should go to terminal 20. The ground wire should go to ground.
- The fluid level float switch (Figure 5.4-3) connects Block J9 and Input 10. Using the brown and white wires to terminals 19 and 20 respectively.

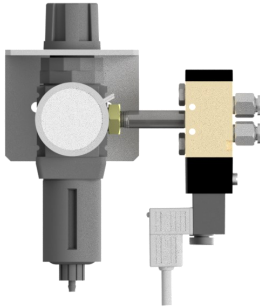

Figure 5.4-1: Air Pressure Regulator



Figure 5.4-2: Solenoid Cable



Figure 5.4-3: Fluid Level Float Switch



ATTENTION: Be sure to follow all local and national electrical codes.

5.5 AIR PRESSURE REGULATOR

The following images may or may not depict your exact system configuration. Function will remain consistent regardless of configuration.

SETTING THE SYSTEM AIR PRESSURE

Note: During the initial pressure setting, the adjustment knob may be difficult to unlock. If this happens, disconnect the compressed air line and unlock the adjustment knob and then reconnect the compressed air line.

Pull the black adjustment knob of the air pressure regulator outward (away from the gauge) until it clicks. This will unlock the adjustment knob and allow the pressure setting to be changed.

With the compressed air line connected, adjust the air pressure regulator setting by rotating the adjustment knob until the black set point indicator on the regulator is between 0.27 MPa (40 PSI) and 0.52 MPa (75 PSI). Turning the knob clockwise will increase the pressure setting and counterclockwise will decrease the setting.

- Adjustment knob-Pull the knob away from the regulator body to unlock and adjust the air pressure settings.

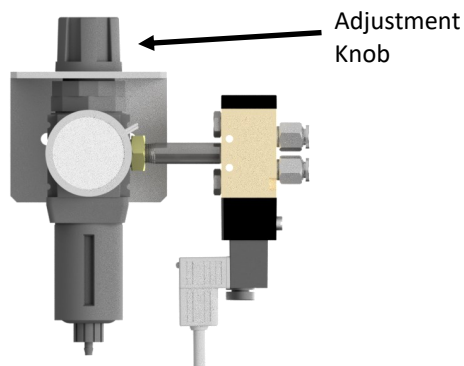

Figure 5.5-1: Air pressure switch, adjustment knob





ATTENTION: The operating pressure of the pumps is 0.1 MPa (14.5 psi) – 0.6 MPa (87 psi). An air pressure setting outside of the pump operating pressures may cause flow problems or pump failures.

When the desired pressure setting is reached, push the adjustment knob towards the air pressure gauge until it clicks. This will lock the adjustment knob in position.

SETTING THE AIR PRESSURE SWITCH

The air pressure switch is used to detect when the air pressure supplied to the system has dropped below the necessary operating pressure to cycle the piston pumps. This signal will relay a low air pressure fault to the spray control panel.

HOW TO SET THE AIR PRESSURE SWITCH

1. The gauge cover must be removed by twisting it counterclockwise until it stops (approx. ¼ inch).
2. Gently pull the cover away from the gauge. Note the catch in the gauge that align with the slot on the gauge cover—this is important when reinstalling the gauge cover.
3. Using a small flathead screwdriver (2.9 mm blade width) adjust the air pressure switch adjustment screw located on the bottom of the gauge until the green indicator pointer is set to 0.3 MPa. (approx. 40 PSI). This is the low air pressure set point.
4. If the compressed air drops below this setting, the switch will alarm the control panel indicating that there is inadequate air pressure to operate the piston pumps. The red LED Stop button on the control panel door will flash 10 times indicating there is low air pressure. The green tabs on the gauge can be used to mark the chosen pressure setting and the chosen low air pressure setting. They have no effect on the actual air pressure setting or air pressure limit switch settings.
5. Once the low air pressure setting is complete, replace the gauge cover by lining up the slot (notch in the cover) to the catch on the gauge housing.
6. Gently push the cover into the gauge and rotate it clockwise until it stops.

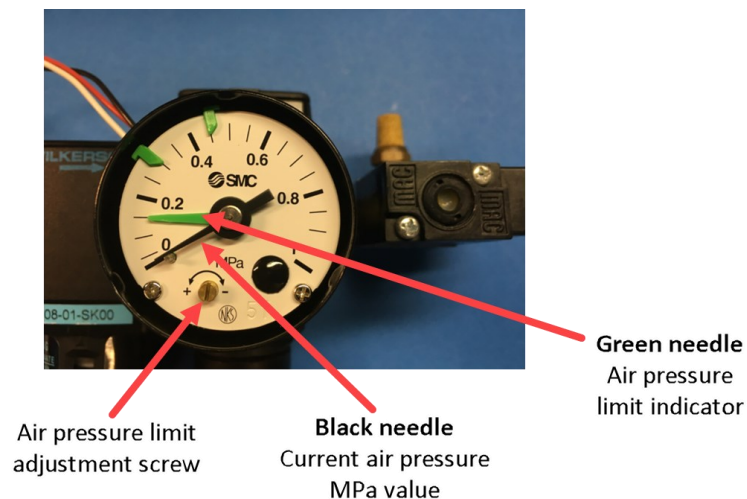

Figure 5.5-2: Air pressure switch, dial

5.6 PARTICULATE FILTER

The particulate filter (five micron) is included to prevent moisture and dirt from entering the solenoid valve by way of the compressed air line. Excess moisture will condense inside the attached polycarbonate bowl. The polycarbonate bowl water level can be viewed through the slots of the metal bowl protector.



CAUTION: Regularly monitor the water level and do not allow it to go above the maximum level indicator. If the water level exceeds the maximum level indicated on the metal bowl cover, water may enter the solenoid valve causing component failure.



Figure 5.6-1: Particulate Filter

DRAINING THE PARTICULATE FILTER BOWL

While the regulator is still under pressure, slowly rotate the drain valve on the bottom of the bowl protector **counterclockwise** until water begins to drain. After all the water is drained, rotate the drain valve **clockwise** to close the drain.



CAUTION: Ensure that the metal bowl protector does not rotate with the drain valve. Hold the metal bowl protector in place while rotating the drain valve if necessary.

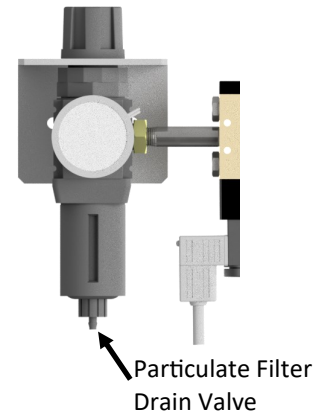

Figure 5.6-2: Drain valve

REPLACING THE PARTICULATE FILTER ELEMENT

1. Disconnect the compressed air line from the filter regulator assembly
2. Open the drain valve on the bottom of the metal bowl protector— This will ensure that no pressurized air remains in the particulate filter.
3. Rotate the metal bowl protector counterclockwise until it stops
4. Pull the bowl protector downward until it releases from the particulate filter body
5. Rotate the black plastic hex nut counterclockwise to unscrew it from the filter body until it is removed
6. Remove the filter element and replace it with a clean new one
7. Reinstall the hex nut and the metal bowl protector and close the drain valve
8. Reconnect the compressed air line

5.7 VERIFYING THE FLUID RESERVOIR ASSEMBLY SET UP

Check that the following has been completed:

- The air pressure switch, solenoid cable, and fluid level float switch are wired into the spray control panel
- The air pressure switch is securely connected to the compressed air line, and the switch is securely connected to the pump
- The pump output line is securely connected to the fluid input on the electrostatic nozzle



ELECTROSTATIC CHAIN OILER SPRAY NOZZLE

6.1 NOZZLE OVERVIEW

ELECTROSTATIC CHAIN OILER SPRAY NOZZLE

The Electrostatic Chain Oiler Spray Nozzle delivers the electrostatically charged fluid to the target. Using the spray control panel, operators can adjust the voltage level applied to all nozzles that are connected to that panel. Each nozzle is connected to its own individual piston pump, which allows for some independent adjustment of pump flow rate.

The nozzle tip should be able to be adjusted to between 1/2" to 1" away from the target to allow for electrostatic spray fine tuning. This can affect the electrostatic spray at each nozzle, and allows for process-specific customization of spray capacity, spray pattern, and electrostatic droplet size.

The Chain Oiler Spray Nozzle is a versatile and compact electrostatic single-orifice nozzle. Operators can adjust the applied voltage and fluid flow rate to all Chain Oiler Nozzles in use with the spray control panel and the fluid delivery system.

MOUNTING

- The Chain Oiler Nozzle includes a 7/8 in. 20UNEF-2A thread for mounting
- The nozzle must be mounted in a clean, non-hazardous area
- The nozzle must be mounted in a location where the chain is extremely steady
 - Any movement of the chain could cause an arc or damage the nozzle tip
- The spray target must be properly grounded
- The ground wire should go directly to an earth ground as defined by local electrical codes.



ATTENTION: Nothing metallic or conductive, except for the target, should be within a 8 in. envelope of the nozzle. Any mounting fixtures should be made of nonconductive materials.

The nozzle mounting scheme should allow for as many degrees of nozzle movement as possible. This allows for easier fine tuning and adjustment of the electrostatic spray.

The nozzle should be able to move so that the nozzle tip can be positioned between 1/2 in. to 1 in. away from the target.

0.27" Plastic Mounting
Screws Recommended
to Prevent Arcing

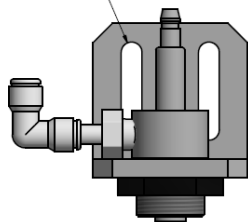

Figure 6.1-1: Chain Oiler nozzle mounting

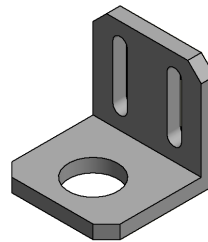

Figure 6.1-2: Nozzle mounting bracket

MOUNTING BRACKET

The mounting bracket is compatible with the nozzle mounting threads and includes two 0.270 in. (6.9 mm) slots.

6.2 NOZZLE CONNECTIONS

Fluid Line

Fluid line tubing must be made from a material that is compatible with the fluid being sprayed. Tubing must be rigid enough to be compatible with the 1/4 in. (6.4 mm) OD push-to-connect fittings that are supplied with the nozzle assembly.

—All fluid must be run through a filter capable of removing 90 micron particulates.



CAUTION: Metallic tubing is not to be used as it will interfere with the electrostatic fields and create arcing.

Depending on the pump flow rate and length of line, purging all air from the fluid lines can take an extended period of time. It is suggested that a syringe, pressure pot, or other higher flow device be used to purge the line.

HIGH VOLTAGE CABLE

The high voltage cable connects the HVPS from the Spray Control Panel terminal block to the nozzle. The electrode connector connects into the rubber boot at the end of the high voltage cable with a steel fastener.

—Ensure that the fastener is firmly attached to the nozzle electrode connector.

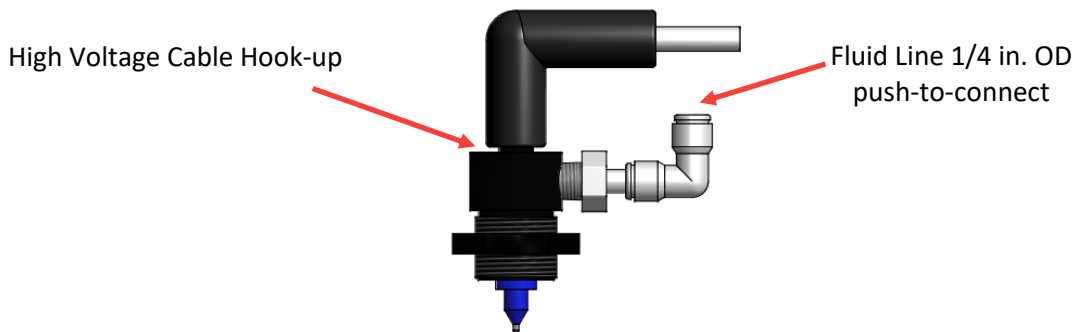

Figure 6.2: Chain oiler nozzle connections

6.3 NOZZLE DISASSEMBLY PROCEDURE



WARNING: Make sure that power has been turned off and disconnected from the Spray Control Panel before starting nozzle disassembly.

Reverse the disassembly procedure when its time to reassemble the nozzle.

- i) Disconnect and remove the high voltage cable (6)
- ii) Remove the nozzle tip (1) from the nozzle body (4) using a 7/16 wrench
- iii) Remove the hex nut (2) from the nozzle body (4)
- iv) Slide the mounting bracket (3) away from the nozzle body (4)
- v) Remove the fluid line push-to-connect fitting (5)

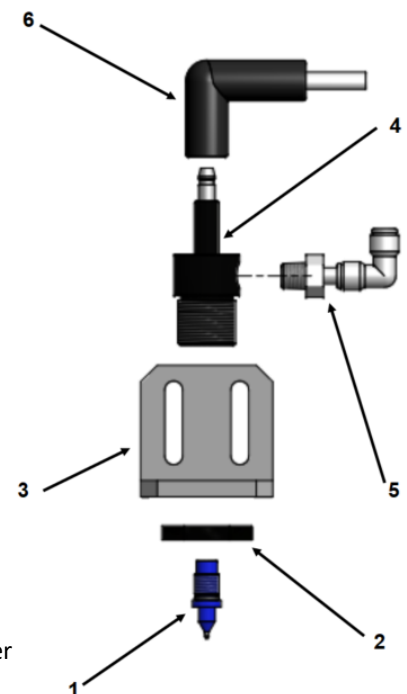

Figure 6.3: Chain oiler nozzle disassembly



6.4 NOZZLE CONFIGURATION AND ADJUSTMENT

ELECTROSTATIC VOLTAGE

The electrostatic nozzle is rated for between 0–30,000 volts. This voltage range allows for variation in fluid viscosities and allows for adjustments to both spray pattern and drop size.



WARNING: Do not exceed voltage rating for nozzle assembly. Serious injury or death may occur.

Initial Nozzle Configuration

1. Begin with the nozzle tip positioned 1/2 in. (12.7 mm) to 3/4 in. (19 mm) away from the target.
2. Position the nozzle tip so that it is pointing at the area where the spray is desired. This position may need to be adjusted when the nozzle is spraying as other grounded objects nearby may influence the spray pattern.
3. Apply the desired flow rate to the nozzle.
4. Allow enough time for fluid to start dripping from the nozzle tip before applying voltage.
5. Start with the voltage at zero and slowly increase—watch for the drops on the tips of the spray nozzles to form into a small cones. These small cones will have a series of single file droplets propelling off from the tip. At the lower end of the voltage range, the droplets will be heavier with spaces in between.
6. As voltage is increased, droplets will shrink and appear to be one very thin, continuous stream. **This continuous stream is considered to be a proper spraying nozzle.**

ADJUSTMENT OF SPRAY

If the spray pattern appears intermittent or has heavy drops, try one or both of the following:

1. Increase the applied voltage.
2. Move the nozzle tip closer to the grounded target. Ensure that the nozzle tip does not come into contact with any moving parts. If any damage occurs to the nozzle tip, it will need to be replaced—defects in the tip will affect the spray pattern.

—If arcing occurs: See Section 7.4 Arc Fault Troubleshooting.

ELECTROSTATIC FIELD

To control or make adjustments to the electrostatic field:

- Change the distance between the nozzle and target.
- Change the voltage applied to the nozzle.

The distance between the nozzle and the target will also influence any arcing of the nozzle. If the Spray Control Panel detects an arc, it will display a fault.



FAULTS AND TROUBLESHOOTING

7.1 FAULTS AND FAULT CODES

The system can generate one fault code at a time. If a second fault condition occurs, it will register after the reset button has been pressed and the first fault has been resolved.

The Stop button LED will display a 250 mS ON pulse (button illuminated) followed by a 250 mS OFF pulse (button not illuminated). Once the number of pulses flash for the current system error, the pulse sequence will repeat after a one second pause.

Fault Code	Stop Button LED Indicator	Description
Stop Fault	Illuminated, no pulsing	Occurs when the Stop Button on the panel door is pressed. Stops system operation, all lubrication outputs and the HVPS will be disabled.
Arc Fault	Continuously pulsing	Occurs when too much current flows through the HVPS. —See: <i>Arc Fault Troubleshooting</i>
Nozzle 1 Pressure Low Fault	Pulses 2 times	Time delayed fault— when a pressure or flow sensor detects problems with fluid delivery to the nozzles.
Nozzle 1 Pressure High Fault	Pulses 4 times	Time delayed fault— when a pressure or flow sensor detects problems with fluid delivery to the nozzles.
Nozzle 2 Pressure Low Fault	Pulses 6 times	Time delayed fault— when a pressure or flow sensor detects problems with fluid delivery to the nozzles.
Nozzle 2 Pressure High Fault	Pulses 8 times	Time delayed fault— when a pressure or flow sensor detects problems with fluid delivery to the nozzles.
Low Air Pressure Fault	Pulses 10 times	Indicates an open air pressure switch. —When the air supply pressure drops below the required pressure, the switch will open and latch the spray control panel into a fault.
Low Reservoir Fault	Pulses 12 times	Indicates that the reservoir fluid level has fallen to an unsafe operating level. —When the fluid level drops below the float sensor level, the switch will open and the system will latch into a fault .

NOZZLE PRESSURE LOW FAULT

Low fluid pressure can indicate a faulty pump, a faulty pump solenoid, or a leak in the tubing connecting the pump to the nozzle.

NOZZLE PRESSURE HIGH FAULT

High liquid pressure can indicate an obstruction in the fluid delivery system, such as debris in the nozzle spray tube.



7.2 FAULT LED STATUS

Fault LED Status: Steady Illumination—Stop Fault	
Cause	Solution
STOP button has been pressed	Press the RESET button on the spray control panel door
Wire from STOP button or terminal block is disconnected	Repair the connection and press RESET button on the spray control panel door
STOP button contact block is faulty	Replace the contact block and press RESET on the spray control panel door
Fault LED Status: Continuous Pulsing—ARC Fault	
Cause	Solution
High voltage output is set too high	Adjust the high voltage potentiometer and press the RESET button on the spray control panel door
Nozzle is too close to target	Increase the distance between nozzle and target
Air pocket in nozzle	Ensure that the nozzle has no air gaps that can cause an arc internally in the nozzle then press the RESET button on the spray control panel door
Faulty Cable	Replace the cables then press the RESET button on the spray control panel door
Liquid being sprayed is too conductive	If the fluid is too conductive, it will need to be changed before the electrostatic system can be used again
Fault LED Status: 2 Pulses—Nozzle 1 Pressure Low Fault	
Cause	Solution
Input 5 sensor switch open	Correct the condition that opened the switch, then press the RESET button on the the spray control panel door
Input 5 is not being utilized and Input 5 Bypass DIP Switch is in “OFF” position	If the input is not being used, the Input Bypass DIP Switch must be in the “ON” position. Put switch in “ON” position then press the RESET button on the the spray control panel door
Fault LED Status: 4 Pulses—Nozzle 1 Pressure high Fault	
Cause	Solution
Input 6 sensor switch open	Correct the condition that opened the switch then press the RESET button on the spray control panel door
Input 6 is not being utilized and Input 6 Bypass DIP Switch is in “OFF” position	If the input is not being used, the Input Bypass DIP Switch must be in the “ON” position. Put switch in “ON” position then press the RESET button on the spray control panel door

Fault LED status: 6 Pulses—Nozzle 2 Pressure Low Fault

Cause	Solution
Input 7 sensor switch open	Correct the condition that opened the switch then press the RESET button on the spray control panel door
Input 7 is not being utilized and Input 7 Bypass DIP Switch is in “OFF” position	If the input is not being used, the Input Bypass DIP Switch must be in the “ON” position. Put switch in “ON” position then press the RESET button on the spray control panel door

Fault LED status: 8 Pulses—Nozzle 2 Pressure Low Fault

Cause	Solution
Input 8 sensor switch open	Correct the condition that opened the switch then press the RESET button on the spray control panel door
Input 8 is not being utilized and Input 8 Bypass DIP Switch is in “OFF” position	If the input is not being used, the Input Bypass DIP Switch must be in the “ON” position. Put switch in “ON” position then press the RESET button on the spray control panel door

Fault LED status: 10 Pulses—Low Air Pressure Fault

Cause	Solution
Air Pressure drops below Air Pressure Switch Set Point	Correct the low air pressure condition then press the RESET button
Air leak(s) causing inadequate air to the regulator assembly	Repair the air leak(s) then press the RESET button
Loose wire or connection on Input 9 terminal block	Tighten the terminal block screws, then press the RESET button
Faulty air pressure switch	Replace the air pressure switch, then press the RESET button
Air pressure switch not being used and Input 9 Bypass DIP Switch is in “OFF” position	If the input is not being used the Input Bypass DIP Switch must be in the “ON” position. Put switch in “ON” position then press the RESET button

Fault LED status: 12 Pulses—Low Reservoir Fault

Cause	Solution
Fluid level in reservoir has dropped below the switch level	Fill the reservoir, then press the RESET button
Loose wire or connection on Input 10 terminal block	Tighten the terminal block screws, then press the RESET button
Faulty reservoir level switch	Replace the reservoir level switch, then press the RESET button
Reservoir level switch not being used and Input 9 Bypass DIP Switch is in “OFF” position	If the input is not being used, the Input Bypass DIP Switch must be in the “ON” position. Put switch in “ON” position, then press the RESET button



7.3 GENERAL SYSTEM TROUBLESHOOTING

If any system or system component malfunctions occur, **shut off** the system immediately and perform the following steps:

- Disconnect and lock out electrical power
- Close pneumatic shutoff valves and relieve the pressure
- Identify and correct the malfunction before restarting the system
- Check all pneumatic, hydraulic, and electrical connections

Problem: no fluid at spray nozzles	
Cause	Solution
Improper adjustment at the injector pump	Adjust pump flow by turning the liquid output adjustment stem
Damaged or leaking lubricant lines	Inspect, identify, and replace lines
Clogged or leaking injector pump	Clean or replace pump
Clogged spray nozzle(s)	Flush spray nozzle with hot water/detergent solution. Dry before reuse. Or, replace nozzle.
Fluid lines not primed	Put the system into PRIME mode
Problem: lubricant coming out in drips	
Cause	Solution
Low high-voltage setting	See high-voltage output potentiometer
Improper connection between HV cables	Tighten each HV cable connection and make sure it is clean of any dirt and/or foreign particles
HV power supply malfunction	Replace HV power supply
Improper grounding	Ensure all grounding connections are secure for the HV cables
Problem: Injector Pump Not Cycling	
Cause	Solution
Low air pressure	Check for Air Pressure Fault Code. Correct low pressure condition and press reset button.
Malfunctioning solenoid valve	Replace solenoid valve
Problem: Arcing Near the Machine	
Cause	Solution
Surrounding machinery not grounded	Connect grounding cables to machine base and connect earth ground to machine base

7.4 ARC FAULT TROUBLESHOOTING



CAUTION: Place the ends of the disconnected cables at least six (6) inches away from any grounded surface.

Arc Faults	
Cause	Solution
Visible electrical arc at the nozzle after pressing the TEST button	<p>Move the nozzles further away from the target and try again.</p> <p>Purge the fluid lines to remove any possible air pockets in the nozzle</p>
General arc fault	<p>Lower the high voltage output by turning the H.V. ADJ potentiometer dial counterclockwise. Press the TEST button on the control panel circuit board and check the nozzle output.</p> <p>Slowly turn the H.V. ADJ potentiometer adjustment dial clockwise until the spray from the affected nozzle becomes a thin steady stream.</p>
Additional Arc Fault Troubleshooting	
<p>If the system still faults, press the STOP button disconnect the cables from the spray control panel. Press the RESET button, then the TEST button on the control panel circuit board.</p>	
<p>If the system still faults with no cables connected, there is a problem inside the spray control panel. Consult your local Spray Specialist.</p>	
<p>If the system doesn't fault with the cables disconnected, press the STOP button and reconnect the cables at the spray control panel and disconnect the cable from the nozzles.</p>	
<p>Press the RESET Pushbutton then the TEST button on the PCB. If the system faults, then there is a problem with the cables. If the system doesn't fault, the problem is at the nozzle.</p>	
Arc Faults Originating At The Nozzles	
Solution	
<p>Purge fluid lines to ensure no air pockets are trapped in the nozzles</p>	
<p>Move the nozzle back and further away from the spray target</p>	
<p>With exception of the target, check to make sure there are no grounded objects near the nozzle tip</p>	
<p>Ensure that HV cable silicone boots are tightly connected to the nozzle electrode stem</p>	
<p>Check that all system grounding connections have been made and are secure</p>	



SECTION 8

SPARE AND REPLACEMENT PARTS

System configuration specific spare parts are not universal to all ES250 systems. Take note of which pump configuration, nozzle connection type, and nozzle tip is used with your system prior to ordering any spare parts.

Standard replacement parts are compatible with all ES250 configurations.

System Configuration Specific Spare Parts	
Part	Part Number
PUSH-TO-CONNECT MODULAR NOZZLE ASSY, DELRIN	250TS25000022W0
Push In Style Tip, .020", BLUE	CP102004-601
Push In Style Tip, .030", YELLOW	CP102004-602
THREADED MODULAR NOZZLE BODY ASSY, DELRIN	250TS25000026W0
Push In Style Tip, .020", BLUE	AJ102003-202
Push In Style Tip, .030", YELLOW	AJ102003-203
Standard Replacement Parts	
Part	Part Number
LEVEL SWITCH	SW00101202810
PRESSURE GAUGE W/SWITCH	SW00GP46101X201
HIGH VOLTAGE CABLE 25FT	WX002149SVJ_AC25
HIGH VOLTAGE CABLE 35FT	WX002149SVJ_AC35
Filter, Inline, Air, 1/8 NPT (M), 10 CFM at 100 PSI, 300 PSI Max., 90 microns, Brass	FI0098355K832
filter, strainer, , Exhaust Muffler/Filter, 1/8" NPT(M), 11 SCFM @ 100 PSI, Steel	FI004450K1
Filter/Regulator, Combination, 1/4 NPT, 5-micron, 150 PSI Max., 42 cfm	FC006B315
Reservoir Tank, 16L, w/threaded inserts, Polypropylene	TK00L21016L
Inline Filter, 1/8" NPT, Brass	FI0098355K832
Fitting, Straight, Push-In, 1/8 NPT (F) x 1/4" O.D. Tube, nickel plated brass	PLXXPIBNACAAIB0
Filter/Regulator, Combination, 1/4" NPT, 5-micron, 150 PSI Max., 42 cfm	FC006B315_AC02
L220 Pump Assembly for ES250	PU00D41984L220_AC01
Adapter, 1/4 BSPT (M) x 1/8 NPT (F), 316SS	PL001456N243
Tubing, Nylon, 1/4" O.d. x .035 wall, clear natural, 78R duro, 170 psi @ 150 deg F	FTXXPANL06050B0
Solenoid Valve, 4-2 way, Spring return, 1.8" NPT Female Ports, 24VDC, DIN connection	VC00AVS511124D

© 2024 All rights reserved. Printed in the U.S.A.

Under copyright laws, this manual may not be reproduced in any form, in whole, or in part, without prior written permission from Spraying Systems Co.[®]. This revision supersedes all previous revisions. Every effort has been made to ensure that the information in this manual is accurate at the time of printing.

However, Spraying Systems Co. assumes no liability for errors or omissions and reserves the right to make changes without notice to any products described herein to improve reliability, function, or design. Other company and product names may be trademarks of their respective companies.

Warranty is one (1) year on non-wear parts from ship date. Wear items are covered for manufacturing defect only for a period of one (1) year. Wear items include, but may not be limited to, Liquid pump and Liquid regulator. Seller warrants that its products will conform to and perform in accordance with the products' specifications.

Seller warrants that the products do not infringe upon any copyright, patent, or trademark.

THE FOREGOING WARRANTIES ARE IN LIEU OF ALL OTHER WARRANTIES, EXPRESS OR IMPLIED, INCLUDING, BUT NOT LIMITED TO, THOSE CONCERNING MERCHANTABILITY AND FITNESS FOR A PARTICULAR PURPOSE.



Spraying Systems Co.[®]
Experts in Spray Technology

North Avenue and Schmale Road, P.O. Box 7900, Wheaton, IL 60187 - 7901

Tel: 1.800.95.SPRAY Intl. Tel: 1.630.665.5000

Fax: 1.888.95.SPRAY Intl. Fax: 1.630.260.0842

www.spray.com

