

# TankJet® 80 & 80H Tank Cleaners

USER GUIDE



**Spraying Systems Co.®**  
Experts in Spray Technology

MI-TJ80 & TJ80H  
[spray.com](http://spray.com)

# CONTENTS

---

<b>PRINCIPLES OF OPERATION</b> .....	<b>4</b>	REPLACEMENT PARTS:.....	5
MATERIALS:.....	4	DISASSEMBLY:.....	6
CONSTRUCTION:.....	4	ASSEMBLY.....	6
PRINCIPLE OF ROTATION:.....	4		
CLEANING DIAMETER:.....	4	<b>WARRANTY</b> .....	<b>6</b>
<b>INSTALLATION</b> .....	<b>5</b>	<b>TANKJET 80 PARTS LIST</b> .....	<b>7</b>
<b>OPERATION</b> .....	<b>5</b>	<b>TANKJET 80H PARTS LIST</b> .....	<b>8</b>
OPERATION & SPECIFICATION.....	5	<b>TANKJET SPECIFICATIONS</b> .....	<b>9</b>
<b>TROUBLE SHOOTING</b> .....	<b>5</b>	<b>EC DECLARATION OF INCORPORATION</b> .....	<b>10</b>
<b>SERVICING</b> .....	<b>5</b>		

**IMPORTANT!** *Read all instructions in this manual before operating machine.*



# GENERAL SAFETY INSTRUCTIONS

## READ AND FOLLOWING INSTRUCTIONS:

**WARNING:** All safety related and operating instructions should be read before the nozzle is operated. Follow all operating instructions. Failure to do so could result in serious injury.

- **WARNING:** It is important to recognize proper safety precautions when using a pressurized spray system. Fluids under pressure can penetrate skin and cause severe injury.
- **WARNING:** When dealing with pressure applications, the system pressure should never exceed the lowest rated component. Always know your system and all component capabilities, maximum pressures and flow rates.
- **WARNING:** Before performing any maintenance, make sure all liquid supply lines to the machine are shut off and /or disconnected and chemical/fluid are drained.
- **WARNING:** The use of any chemicals requires careful control of all worker hygiene.
- **WARNING:** Spraying Systems Co. does not manufacture or supply any of the chemical components used in this equipment and is not responsible for their effects. Because of the large number of chemicals that could be used and their different chemical reactions, the buyer and user of this equipment should determine compatibility of the materials used and any of the potential hazards involved.
- **WARNING:** Spraying Systems Co. strongly recommends the use of appropriate safety equipment when working with potentially hazardous chemicals.
- **WARNING:** Before use be sure appropriate connections are secure and made to withstand weight and reaction forces of the operating unit.

This equipment includes but is not limited to:

- Protective hat
- Safety glasses or face shield
- Chemical-resistant gloves and apron
- Long sleeve shirt and long pants



**NOTE:** Always remember to carefully read the chemical manufacturer's label and follow all directions.

**WARNING:** DO NOT USE TO SPRAY FLAMMABLE LIQUIDS – SUCH USE COULD RESULT IN FIRE OR EXPLOSION CAUSING BODILY INJURY OR DEATH.

- **WARNING:** Never operate tank cleaning equipment in the open due to the potential of bodily injury.
- **WARNING:** It is important to operate equipment within the temperature range of all components. Also insure that appropriate time lapses or proper safety equipment is used when handling components after they're exposed to high temperatures.
- **WARNING:** Removed equipment from the tank before attempting any repairs.
- **WARNING:** Proper hoisting procedures should be used when installing and removing all equipment.
- **WARNING:** If walking on top of a tank is deemed safe and is necessary, use proper safety precautions to protect individuals as well as the equipment.
- **WARNING:** Do not put any part of your body in the tank during operation of the tank cleaner. This is NOT a safe procedure for verification of operation.
- **WARNING:** To insure the safety of the equipment as well as the individuals using them, only use Spraying Systems Co. components.
- **WARNING:** When packaging and transporting use structurally sound boxes or crates that can handle the weight of the equipment.
- **WARNING:** Tank cleaners should be flushed out with clean water before they're stored or shipped to minimize health hazards or cross contamination.
- **WARNING:** Do not use any equipment outside the intended purposes of the product. Misuse can result in personal injury or product damage.

The container being cleaned should be sealed as best as possible while the TankJet 80 models are running its cycle. The combination of temperature, cleaning solution, spray impact and the potential toxic materials being cleaned can cause a hazard to anyone in the path of the spray.



## PRINCIPLES OF OPERATION

**NOTE: The unit will only operate properly when mounted in the vertical position (suspended or inverted).**

The TankJet® 80 models are hydraulically driven rotating heads that provides effective control of rotational speed to assure optimum cleaning by the nozzle streams of internal tank surfaces to be cleaned, sanitized, treated, or rinsed. No reduction gears are used and therefore, minimal maintenance is required. The nozzles will provide a complete 360° indexing path in both vertical and horizontal planes, with the index pattern repeating every 45 revolutions. The “clean line” design of the TJ80H unit ensures a minimum of outside crevices in the unit where processing material may accumulate to cause contamination. It may be installed on a permanent basis (C.I.P.) and can clean almost any type of contained area within its range. Many types of fluids, sanitizers, detergents, solvents and caustics may be used through the TankJet 80 to assist in its cleaning effectiveness.

**Caution: If chemicals, hazardous materials, operations, and equipment are used in conjunction with this cleaning equipment, it is the responsibility of the user to establish appropriate associated safety and health practices. Prior to application, the user must consult and determine the applicability of regulatory (federal, state, local and facility) safety and environmental agency limitations.**

## TANKJET 80 MODELS

SSCo. Part #	Description
TJ80*-2-375	Dual 3/8" Nozzle   1.5" NPT
TJ80*-2-438	Dual 7/16" Nozzle   1.5" NPT
TJ80*-2-438SR	Dual 7/16" Nozzle   Slower Rotations   1.5" NPT
TJ80*-2-375CIP	Standard   Dual 3/8" Nozzle   CIP   1.5" NPT
TJ80*-2-438CIP	Dual 7/16" Nozzle   CIP   1.5" NPT
TJ80*-3-375SR	Triple 3/8" Nozzle   Slower Rotations   1.5" NPT
TJ80*-3-375	Triple   3/8" Nozzle   1.5" NPT
TJ80*-3-313	Triple 5/16" Nozzle   1.5" NPT
TJ80*-3-375SRCIP	Triple 3/8" Nozzle   Slower Rotations CIP   1.5" NPT
TJ80*-3-313CIP	Triple 5/16" Nozzle   CIP   1.5" NPT

\*Add B for BSPT connections after the model no.

## TANKJET 80H HYGENIC MODELS

SSCo. Part #	Description
TJ80H*-2-250	Dual 1/4" Nozzles   1.5" NPT
TJ80H*-2-313	Dual 5/16" Nozzles   1.5" NPT
TJ80H*-2-375	Dual 3/8" Nozzle   1.5" NPT
TJ80H*-2-438	Dual 7/16" Nozzle   1.5" NPT
TJ80H*-3-250	Triple 1/4" Nozzles   1.5" NPT
TJ80H*-3-313	Triple 5/16" Nozzle   1.5" NPT
TJ80H*-3-375	Triple 3/8" Nozzle   1.5" NPT
TJ80H*-3-438	Triple 7/16" Nozzle   1.5" NPT

\*Add B for BSPT connections after the model no.

## MATERIALS:

316 Stainless Steel (UNS S31600), PTFE and UHMW-PE

## CONSTRUCTION:

Referring to the Parts List, the unit consists of two basic components; the drive, comprising of the body, motor, rotor, and shaft; and the nozzle head, comprising of the nozzle body, bushings, nozzles, and elbow shaft.

## PRINCIPLE OF ROTATION:

The liquid enters the inlet cap (1) and then flows through the oblique and bypass holes of the inlet disc (6) causing a swirling motion in the liquid. The swirling liquid goes down the outside of the vertical shaft (2) imparting rotation to the 4 tooth impeller (9) and thus the vertical shaft. The liquid then goes thru the holes in the vertical shaft and thru the elbow to the horizontal shaft (15). There is a hole in the elbow allowing a constant stream of liquid to be directed at the gear mesh to help prevent build-up. The liquid flows into the nozzle body and out each nozzle. The rotation of the vertical shaft causes the nozzle head assembly to rotate in a horizontal plane. The water leakage from the bottom of the unit is necessary to lubricate the vertical radial bearings and to flush out particles which may cause the unit to jam. The nozzle bodies rotate in the vertical plane by the meshing of the bevel gears (12 & 16); bevel gear (12) has 45 teeth while bevel gear (16) has 44 teeth. This difference in the number of teeth in each gear indexes the nozzles with each rotation.

## CLEANING DIAMETER:

The cleaning distance is a function of rotational speed and liquid pressure applied. The effective cleaning diameter is 50 ft. (15.3 m). The nozzle extensions (22) concentrates the stream for greater reach. If striping occurs on tank walls then the extensions may be removed. This will provide a thicker stream, but will sacrifice about a 10 ft. (3 m) diameter of throw.



**Caution Pinch Point: Bevel gears on the nozzle hub and body can pinch skin and/or fingers. When handling the TankJet 80 be sure to hold it from the nozzles and not the body.**



## INSTALLATION

The TankJet 80 or TankJet 80H is easy to install as it has a single 1-1/2" female pipe thread connection (NPT or BSPT). It may be installed on a tripod, suspended from a pipe, manhole cover, etc., but the unit must be VERTICAL. In all installations a suitable strainer should be used (such as a 20 Mesh "Y" strainer) to prevent dirt or scale from clogging the waterways or openings.

**WARNING:** *In closed tanks, provisions should be made for adequate venting during operation to allow the escape of any gases or volatile vapors which may be produced during operation.*

## OPERATION

To start the unit, turn on the fluid. An in-line valve is required for a slow build-up of liquid pressure in the unit to prevent "water hammer". To stop the unit, turn off the liquid. The unit should always be handled with caution. Make sure nozzles are screwed on the body and hold TankJet 80 by its nozzle not the body. The nozzle hub will rotate freely and bevel gears can pinch skin and/or fingers. If the unit is dropped or maltreated it may cause internal damage to the drive assembly, which in turn can affect the performance of the unit.

## OPERATION & SPECIFICATION

	TankJet 80	TankJet 80H
Pipe Connection:	1-1/2" Female NPT or BSPT	
Operating Pressure Range:	60 - 200 psi (4.1 - 13.8 bar)	60 - 200 psi (4.1 - 13.8 bar)
Max. Operating Temp:	250° F (121° C)	
Flow Capacity:	50 - 125 gpm (189 - 473 lpm)	60-135 gpm (227 - 511 lpm)
Head Rotation Speed:	3 - 20 RPM	
Effective Cleaning Dia.:	To 50 ft. max. (15.3 m)	To 50 ft. max. (15.3 m)
Nozzle Quantity	2 or 3	
Approximate Weight:	15 lbs (6.8 kgs)	
Material of Construction:	316 Stainless Steel, PTFE, UHMW-PE	
Recommended Strainer: (not included)	20 Mesh (1/32 openings)	

## TROUBLE SHOOTING

Due to the simplicity of the unit, very few problems should occur. If any trouble should arise, the following steps may be taken: Refer to the Parts List.

**A. Check units for external damage, look for evidence of mishandling that may have damaged shafts, bearings, or alignment.**

**B. If the nozzle body fails to rotate and no liquid passes:**

1. Check for liquid pressure and volume at the unit.
2. Check strainer for filter blockage.
3. Remove unit and check for clogged jet holes.
4. With the nozzle removed, recheck for flow through the unit.
5. Remove the inlet cap and check the holes of the inlet disc. Check to see that no foreign material is preventing the unit from rotating.

**C. If the unit fails to rotate and sufficient liquid passes:**

1. Check for freedom of rotation, by hand, in the vertical and rotational axis.
2. If no visible abnormalities are discovered, the unit may have been dropped and internal damage is suspect.
3. If the unit still does not rotate, check for:
  - a. Contamination in the unit.
  - b. Wear of any one of the following parts:  
The bushings, washers, and the rotor.
  - c. Galling and straightness of the shaftsand gear.

REPLACE ALL DEFECTIVE PARTS. NO LUBRICATION!

## SERVICING

### REPLACEMENT PARTS:



When the machine requires replacement parts, only Spraying Systems Co. recommended components should be used to maintain proper machine operation and safety.





## DISASSEMBLY:



Be sure to use caution when handling the TankJet 80. When holding, make sure the nozzles are tightly screwed on the unit and then hold the unit from its nozzle not the body. The nozzle hub will rotate freely from the main body and the bevel gears can pinch skin and/or fingers. Refer to parts list at the back of the manual.

### 1. Removal of nozzle body, elbow and vertical shaft assembly.

- a. Place elbow shaft (14) in a soft vise.
- b. Unscrew inlet cap (1).
- c. Unscrew the hex nut (3) and shaft cap (4).
- d. Remove the thrust washers (5 & 20) and radial bushing (8).
- e. Lift out the inlet disc (6).
- f. Unscrew the impeller (9) from the vertical shaft (2).
- g. Lift the outer body (7) assembly from the vertical shaft.

### 2. Disassembly of lower body assembly

- a. Secure the lower cap (11) assembly and remove the body (7).
- b. Secure the lower cap assembly inverted in a soft vise.
- c. Remove the gear (12) with a spanner wrench.
- d. Remove the thrust washers (17 & 21) from the lower body cap.

### 3. Disassembly of vertical shaft and nozzle body assembly

- a. Loosen the 2 set screws (10) in the elbow (14).
- b. Secure the elbow (14) in a soft vise and remove the nozzles (19) and nozzle extensions (22) and check the condition of the stream straighteners.
- c. Using a rod inserted thru the nozzle body holes, unscrew the shaft from the elbow. Secure the elbow and remove the vertical shaft (2).
- d. Secure the nozzle body and remove the gear (16) with a spanner wrench.
- e. Remove the thrust washers (13 & 17), the horizontal shaft (15), and the radial washer (21).

## TANKJET 80 ASSEMBLY

Be sure to use caution when handling the TankJet 80. When holding, make sure the nozzles are tightly screwed on the unit and then hold the unit from its nozzle not the body. The nozzle hub will rotate freely from the main body and the bevel gears can pinch skin and/or fingers. Refer to parts list at the back of the manual.

### 1. Nozzle body, shafts, and elbow assembly

- a. Insert 1 radial washer (21) into the nozzle body (18) recess.
- b. Insert the horizontal shaft (15), threaded end up, into the nozzle body.

- c. Locate the 3 washers onto the shaft, first washer (13), then washer (17), and finally washer (13), surfaces of the washers with the rounded corners should face away from each other, forming a doughnut shape.
- d. Screw the threaded bevel gear (16) into the nozzle body and torque to 100 ft./lbs.
- e. The nozzle body should spin freely on the shaft.
- f. Screw the horizontal shaft (15) assembly into the elbow (14) by inserting a rod thru the nozzle holes to catch the shaft holes.
- g. Screw the vertical shaft (2) into the elbow.
- h. Install the 2 set screws (10) into the elbow and torque to 20 in/lbs.

### 2. Lower cap assembly

- a. Insert a thrust washer (21), washer (17), and washer (21) into the gear (12), surfaces of the washers with the rounded corners should face away from each other, forming a doughnut shape.
- b. Screw the gear into the lower body cap (11) and torque to 100 ft./lbs.

### 3. Final assembly

- a. Mount the elbow/shaft assembly into a soft vise with the vertical shaft being vertical. Install the impeller (9) onto the shaft.
- b. Screw the outer body (7) onto the lower cap assembly.
- c. Place the inlet disc (6) into the outer body locating the vertical shaft thru the center.
- d. Insert the bushing (8).
- e. Insert the thrust washers into the inlet disc recess, first washer (20), then washer (5), and finally washer (23).
- f. Screw the vertical shaft cap (4) onto the shaft and lock the cap with the lockwasher (23) and hex nut (3). Torque the hex nut to 20 ft./lbs.
- g. The nozzle body assembly should spin freely about the vertical shaft.
- h. Remount the lower body cap flats into a vise and screw the inlet cap (1) to the outer body and torque to 75 ft./lbs.
- i. Install the nozzle extension (22) with the nozzles (19) into the nozzle body (18) and torque to 80 ft./lbs.

## WARRANTY

For newly purchased units the warranty is 18 months from the date of shipment or 12 months from the date of installation, whichever occurs first. This warranty includes manufacturing defects but does not cover the wear parts that include the bushings. This warranty will be void if parts other than those supplied by Spraying System Co. are used.



# TANKJET® 80 PARTS LIST

TU80-2

TU80-3

**NOTE:**  
 APPLY A SMALL AMOUNT OF NEVER-SEIZE LUBRICANT TO ALL THREADS AT ASSEMBLY TO PREVENT GALLING.  
 \*FOR ABCKTU80 REPAIR KIT (INCLUDES ALL ITEM MARKED WITH (\*))

ITEM NO.	DESCRIPTION	TU80-2 QTY.	TU80-3 QTY.	REPL.
1A	INLET CAP, NPT	1	1	
1B	INLET CAP, BSPT			
2	VERTICAL SHAFT	1	1	
3	HEX NUT, 3/8-16	1	1	*
4	VERTICAL SHAFT CAP	1	1	
5	THRUST WASHER-INNER-VERTICAL SHAFT	1	1	*
6	INLET DISK	1	1	
7	OUTER BODY	1	1	
8	RADIAL BUSHING	1	1	*
9	IMPELLER	1	1	
10	SET SCREW, #10-32	2	2	
11	CAP, LOWER BODY	1	1	
12	GEAR, 45 TOOTH	1	1	
13	RADIAL & THRUST WASHER	2	2	*
14	ELBOW	1	1	
15	HORIZONTAL SHAFT	1	1	
16	GEAR, 44 TOOTH	1	1	
17	THRUST WASHER INNER-HORIZONTAL SHAFT	2	2	*
18A	NOZZLE BODY (FOR 2 NOZZLES)	1	0	
18B	NOZZLE BODY (FOR 3 NOZZLES)	0	1	
19	NOZZLE	2	3	
20	THRUST WASHER OUTER-VERTICAL SHAFT	2	2	*
21	RADIAL WASHER	3	3	*
22	NOZZLE EXTENSION WITH STREAM STRAIGHTENER	2	3	
23	WASHER, SPLIT LOCK	1	1	
24	CIP NOZZLE ASSEMBLY (CIP MODELS ONLY)	1	1	

TORQUE SPECIFICATIONS	ITEM NO.	TORQUE
WHILE HOLDING ITEM	1	11 TO 75 FT.-LBS.
	3	20 FT.-LBS.
	10	20 IN.-LBS.
	12	100 FT.-LBS.
	16	100 FT.-LBS.
WHILE HOLDING ITEM	19	18 TO 80 FT.-LBS.

**DESCRIPTION:**  
 No. TU80-2-\_\_\_\_, No. TU80-3-\_\_\_\_ &  
 No. TU80-2-\_\_\_\_, No. TU80-3-\_\_\_\_  
 TANKJET

**Rev. No.** \_\_\_\_\_ **Ref.** \_\_\_\_\_

**Parts List No.**  
**PL TU80**  
**SHEET OF**

© Spraying Systems Co.

# TANKJET® 80H PARTS LIST

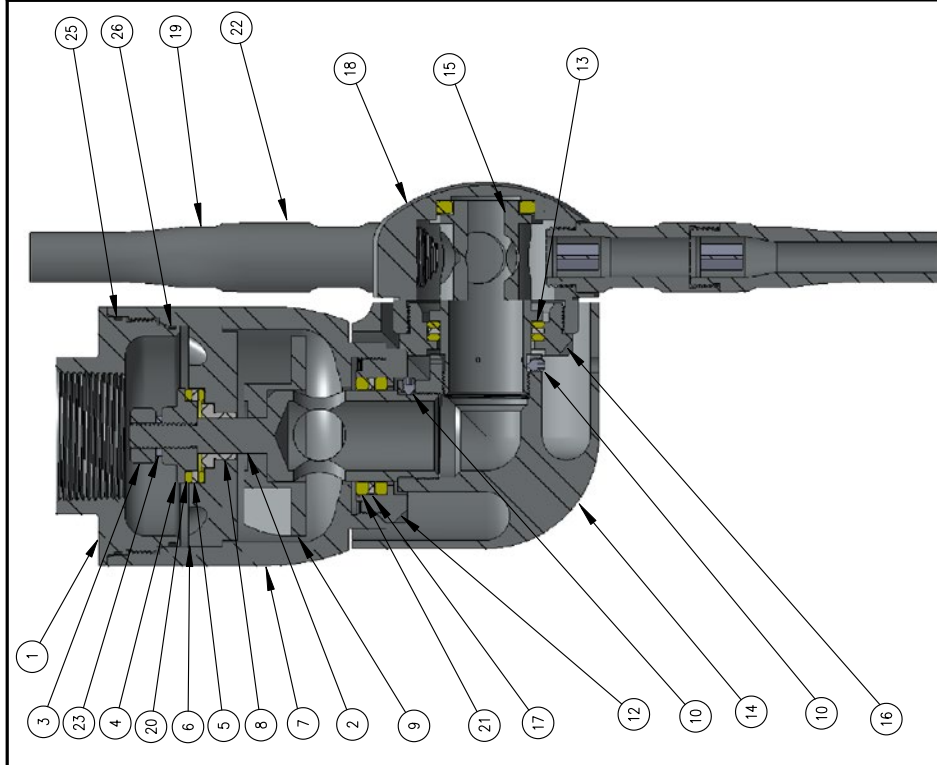

Item No.	Description	TJ80H-2 QTY.	TJ80H-3 QTY.	Repl.
1-A	Inlet Cap, NPT	1	1	
1-B	Inlet Cap, BSPT	1	1	
2	Vertical Shaft	1	1	*
3	Hex Nut, 3/8-16	1	1	
4	Vertical Shaft Cap	1	1	
5	Thrust Washer Inner-Vertical Shaft	1	1	*
6	Inlet Disc	1	1	
7	Main Body	1	1	
8	Radial Bushing	1	1	*
9	Impeller	1	1	
10	Set Screw, #10-32	2	2	
12	Gear, 45 Tooth	1	1	
13	Radial & Thrust Washer	2	2	*
14	Elbow	1	1	
15	Horizontal Shaft	1	1	
16	Gear, 44 Tooth	1	1	
17	Thrust Washer Inner-Horizontal Shaft	2	2	*
18-A	Nozzle Body (For 2 Nozzles)	1	0	
18-B	Nozzle Body (For 3 Nozzles)	0	1	
19	Nozzle	2	3	
20	Thrust Washer Outer-Vertical Shaft	2	2	*
21	Radial Washer	3	3	*
22	Nozzle Extension With Stream Straightener	2	3	
23	Washer, Split Lock	1	1	
25	Upper O-Ring - 236	1	1	
26	Lower O-Ring - 234	1	1	

NOTES:  
 1. Apply A Small Amount Of Never-Sieze Lubricant To All Threads At Assembly To Prevent Galling

\* ABCKTJ80-KIT Repair Kit (Includes All Items Marked With (\*))

Description:  
**Hygienic TankJet® 80 Assembly**



**Spraying Systems Co.**  
 Spray Nozzles and Accessories  
 P.O. Box 7900 - Wheaton, IL 60187-7901

Rev. No. 1  
 Ref. -

Parts List No.  
 PL TJ80H

Sheet - Of -



# SPECIFICATIONS

## 80-2

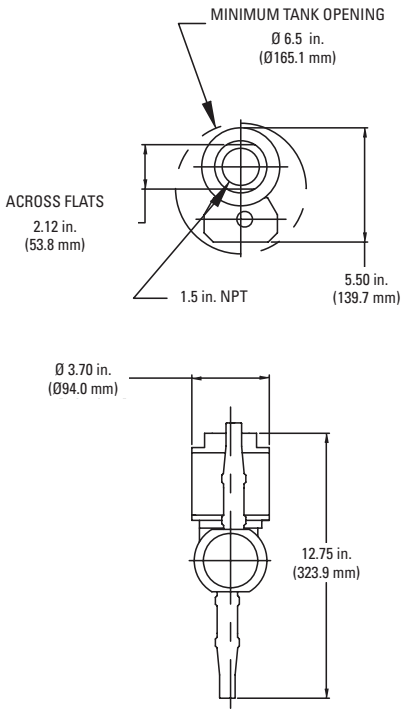

## 80-3

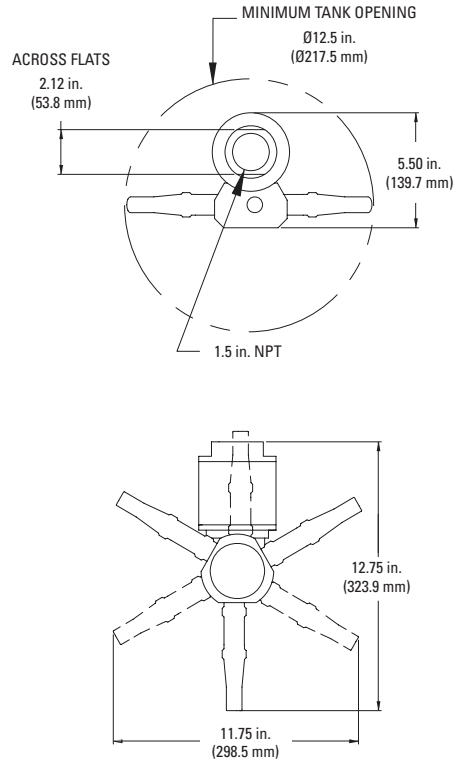

## 80H-2

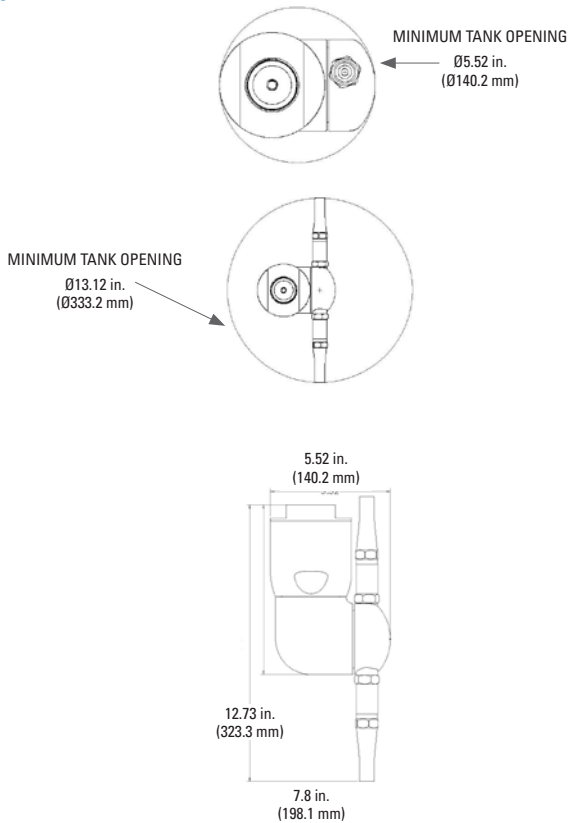

## 80H-3

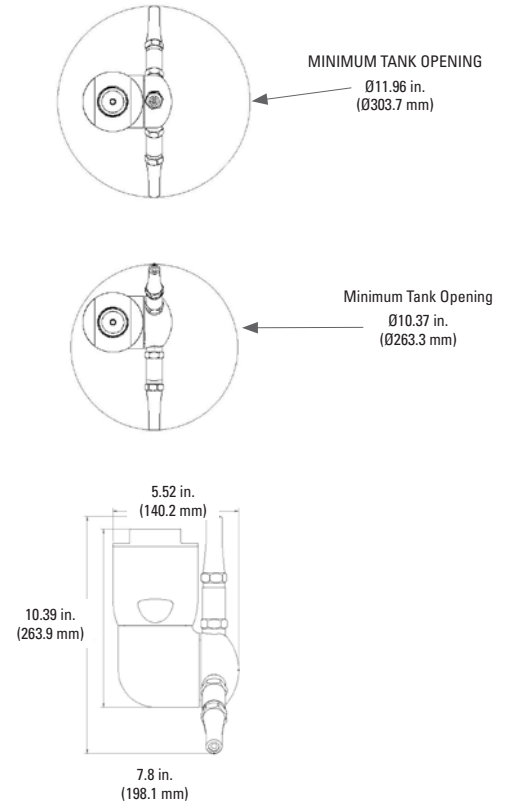

# EC DECLARATION OF INCORPORATION

We, **Spraying Systems Co.**<sup>®</sup>

North Avenue and Schmale Road, P.O. Box 7900,  
Wheaton, IL 60187-7901

Tel: 1.800.95.SPRAY                      Intl. Tel: 1.630.665.5000

Fax: 1.888.95.SPRAY                      Intl. Fax: 1.630.260.0842

Visit our Website at <http://www.spray.com> for local representatives

**in accordance with the following directive(s):**

2006/42/EC                      The machinery directive

**hereby declare that:**

Equipment                      Tank Cleaning Devices, Fluid driven

Model number                      TankJet<sup>®</sup>80, TankJet<sup>®</sup>75, TankJet<sup>®</sup>65

**is in conformity with the applicable requirements of the following documents:**

Ref. no.	Title	Edition/Date
EN ISO 4413	Hydraulic fluid power — General rules and safety requirements for systems and their components	2010
EN 12100	Safety of machinery – General principles for design Risk assessment and risk reduction	2010
BS EN ISO 14121-1	Safety of machinery – Risk assessment Part 1: Principles	2007
ASME- B31.1	ASME Code for Pressure Piping	2020

I hereby declare that the equipment named above has been designed to comply with the relevant sections of the above referenced specifications. The unit complies with all applicable Essential Requirements of the Directives.

Signed by:



Robert J. Adams, P.E.  
Director of Engineering-Industrial Division  
Spraying Systems Co.







***Spraying Systems Co.***<sup>®</sup>

Experts in Spray Technology

P.O. Box 7900, Wheaton, IL 60187-7901 USA

Tel: 1.800.95.SPRAY    Intl. Tel: 1.630.665.5000

Fax: 1.888.95.SPRAY    Intl. Fax: 1.630.260.0842

[www.spray.com](http://www.spray.com)